

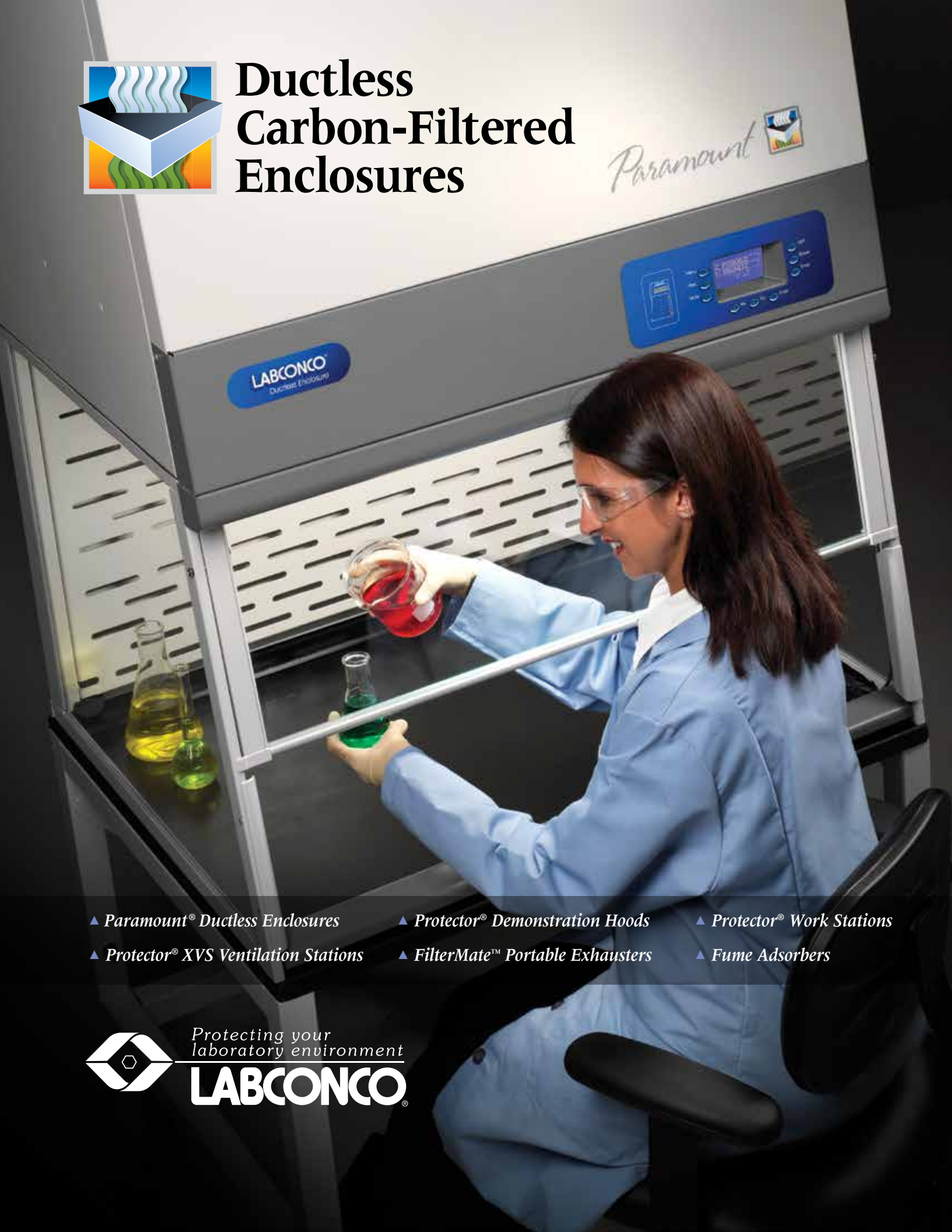

# Ductless Carbon-Filtered Enclosures

Paramount 

LABCONCO  
Ductless Enclosure



▲ Paramount® Ductless Enclosures

▲ Protector® Demonstration Hoods

▲ Protector® Work Stations

▲ Protector® XVS Ventilation Stations

▲ FilterMate™ Portable Exhausters

▲ Fume Adsorbers



Protecting your  
laboratory environment

**LABCONCO**®



# Ductless Carbon-Filtered Enclosures

## OVERVIEW

### Table of contents

|   |    |
|---|----|
| Paramount® Ductless Enclosures .....      | 4  |
| Carbon & HEPA Filters .....               | 8  |
| Accessories .....                         | 9  |
| Fume Adsorbers .....                      | 10 |
| Protector® XVS™ Ventilation Stations..... | 12 |
| Protector® Work Stations.....             | 15 |
| Protector® Demonstration Hoods.....       | 18 |
| FilterMate™ Portable Exhausters.....      | 20 |
| Accessories.....                          | 22 |
| Standards & Registered Trademarks.....    | 26 |



Paramount Ductless Enclosures offer Labconco's broadest range of widths, depths and heights as well as the most filter type choices. Two types of filters may be stacked for mixed use applications.

Ductless Carbon-Filtered Enclosures (often referred to as Ductless Hoods) are viable alternatives to the traditional ducted fume hood when working with volatile chemical fumes and vapors. As defined by SEFA 9-2010 (Recommended Practices for Ductless Enclosures), three categories of "ductless hood" (DH) exist.

**DH I** – A ductless hood equipped with a filtration device designed to control non-toxic chemicals, nuisance odors and particulates.

**DH II** – A ductless hood capable of meeting all DH I requirements, and equipped with a filtration device designed to filter manufacturer-approved toxic contaminants up to filter break through only.

**DH III** – A ductless hood capable of meeting all DH II requirements, and equipped with a filtration device designed to filter manufacturer-approved toxic contaminants beyond primary filter break through by providing secondary back-up protection.

Ductless enclosures offer these advantages and more:

- ▲ **FLEXIBLE** – They can be utilized and flexible in hard-to-duct areas such as the center or bottom level of multi-level buildings.
- ▲ **TURNKEY** – Installation expenses are far less than traditional hoods because no ductwork and remote blower are required.
- ▲ **PORTABLE** – Since they are portable, they may be shared among several laboratories or stored when not in use.

- ▲ **SUSTAINABLE** – Since they have no make-up air requirements, they may be used in air-starved laboratories or offset air requirements of ducted fume hoods.
- ▲ **GREEN** – Unlike traditional fume hoods, costly tempered room air is not exhausted from the laboratory, resulting in lower energy costs.

Labconco offers several options when choosing a Ductless Carbon-Filtered Enclosure. The Selection Guide below lists the enclosures according to their DH category and provides a summary of the range of dimension and filter choices available for each.

### Selection Guide

| Ductless Enclosure  | Overall Width          | Inside Depth | Inside Height       | Filter Types Available* |    |      |    |     |       |      |
|---|------------------------|--------------|---------------------|-------------------------|----|------|----|-----|-------|------|
|   |                        |              |                     | OV                      | AG | FORM | AM | RAD | MIXED | HEPA |
| <b>DH II Enclosures: Suitable for toxic levels of certain chemicals</b>   |                        |              |                     |                         |    |      |    |     |       |      |
| Paramount Ductless Enclosure  | 2', 3', 4', 5', 6'     | 23.4", 30.0" | 22.7", 32.0", 35.0" | •                       | •  | •    | •  | •   | •     | •    |
| <b>DH I Enclosures: Suitable for nuisance odors and non-toxic levels of certain chemicals and particulates.</b> |                        |              |                     |                         |    |      |    |     |       |      |
| Protector® XVS Ventilation Station connected to FilterMate™ Portable Exhauster                                  | 2', 3', 4', 5', 6', 8' | 23.4", 30.0" | 22.3", 31.5"        | •                       |    | •    | •  |     |       | •    |
| Protector® Demonstration Hood connected to FilterMate™ Portable Exhauster                                       | 3'                     | 23.0"        | 22.3", 31.5"        | •                       |    | •    | •  |     |       | •    |
| Protector® Work Station   | 4'                     | 17.2"        | 20.0"               | •                       |    | •    | •  |     |       |      |
| Fume Adsorber   | 2.5', 5'               | 14.5"        | 13.5"               | •                       |    | •    | •  |     |       |      |

\* See filter descriptions on page 3. OV = Organic Vapor, AG = Acid-Sulfur Gases, FORM = Formaldehyde/Formalin, AM = Ammonia-Amines, RAD = Radioisotopes, Mixed = Mixed Bed (Organic Vapor, Acid-Sulfur, Ammonia-Amine, Formaldehyde), HEPA = 99.99% efficient Particulate



# Ductless Carbon-Filtered Enclosures

## OVERVIEW

Labconco, an industry leader in laboratory ventilation since the 1930's, is dedicated to providing world class safety enclosures for your space. Whether or not a ductless carbon-filtered enclosure is the right ventilation product for your application requires consideration of factors such as the time-weighted exposure limits of your materials. The Application Matrix below provides examples of appropriate uses for carbon and HEPA filters used in Labconco enclosures. Depending on the Labconco enclosure, several filter types may be used.

To determine if your application is suitable for a ductless enclosure, Labconco offers an exclusive **Chemical Assessment** available at [www.labconco.com](http://www.labconco.com). After submitting your assessment form, a Labconco specialist analyzes your chemical applications and provides you with a report recommending the appropriate enclosure. Once installed, Labconco website tools keep you informed. The **Filter Reminder Service** alerts you with emails when it is time to check or change your filters. The online **Chemical Guide** provides a reference to check a specific chemical's suitability for a ductless enclosure.

- ▲ **Organic Carbon Filters** are suitable for vapors from solvents including acetone, ethyl acetate, toluene and xylene.
- ▲ **Acid-Sulfur Carbon Filters** are suitable for acid and sulfur gases.
- ▲ **Ammonia Carbon Filters** are suitable for ammonia and low molecular weight amines.
- ▲ **Formaldehyde Carbon Filters** are suitable for vapors from formaldehyde, formalin and gluteraldehyde.
- ▲ **Radioisotope Carbon Filters** are suitable for iodine radioisotope vapors.
- ▲ **Mixed Bed Carbon Filters** are a combination of Organic, Acid-Sulfur, Formaldehyde and Ammonia media.
- ▲ **HEPA Filters**, 99.99% efficient, are suitable for removing particulates such as powders and pollen. They should not be used to capture biohazardous materials or volatile organic material.



Sign up at  
[labconco.com](http://labconco.com)



For light duty applications, Protector XVS Ventilation Stations may be paired with FilterMate Portable Exhausters, which return filtered air to the laboratory.

## Application Matrix

| Filter Type   | Organic | Acid-Sulfur | Ammonia | Formaldehyde | Radioisotope | Mixed Bed | HEPA | HEPA + Carbon* |
|---|---------|-------------|---------|--------------|--------------|-----------|------|----------------|
| Acid pouring and mixing   |         | •           |         |              |              | •         |      |                |
| Asbestos handling   |         |             |         |              |              |           | •    |                |
| Cleanroom/critical environment                                  |         |             |         |              |              |           |      | •              |
| Combination dry and liquid chemicals                            |         |             |         |              |              |           |      | •              |
| Endoscopy instrument cleaning                                   |         |             |         | •            |              |           |      |                |
| Fertilizer research   |         |             | •       |              |              |           |      |                |
| Histology/cytology tissue staining, coverslipping               | •       |             |         |              |              | •         |      |                |
| Hormone research  |         |             |         |              |              |           | •    | •              |
| Iodine isotope handling   |         |             |         |              | •            |           |      |                |
| Non-biohazardous microbiological samples with trace chemicals** |         |             |         |              |              |           |      | •              |
| Particulates in conjunction with chemical agents                |         |             |         |              |              |           |      | •              |
| Pathology/tissue grossing                                       |         |             |         | •            |              | •         |      |                |
| Pollen handling   |         |             |         |              |              |           | •    |                |
| Science education   |         |             |         |              |              | •         |      |                |
| Soldering   | •       |             |         |              |              |           |      | •              |
| Solvent cleaning, welding/gluing                                | •       |             |         |              |              | •         |      |                |

\*A combination of HEPA filter(s) and any other carbon filter type appropriate to the application may be used in either a Paramount Ductless Enclosure or FilterMate Portable Exhauster.

\*\*Ductless carbon-filtered enclosures are not designed to accommodate changing and disposal of biohazardous filters and materials and, therefore, should not be used as biosafety enclosures.



# Paramount® Ductless Enclosures

Paramount® Ductless Enclosures are self-contained while allowing for safe handling of organic, formaldehyde, acid gas, sulfur compounds or ammonia chemical fumes and vapors as well as particulates. Air inside the enclosure passes through carbon filters and, in some

cases additional HEPA filters, before being safely exhausted back into the laboratory.

Two filter types may be stacked for mixed chemical or combination gaseous/particulate applications. No outside ducting is required.

**Electronic security lock**, when enabled, prevents operation of the enclosure by unauthorized users. The user must enter the proper sequence of keystrokes to begin operation.

**Fluorescent light** illuminates the interior. Timer may be set for a specific time period for energy-savings as well as a safeguard for light-sensitive materials.

**Upper dilution air supply** sweeps clean air to the back of the sash to keep contaminants away from the operator.

**Upper containment sash foil** directs contaminants away from the user's breathing zone.

**Side-entry air foils** allow air to sweep interior surfaces to enhance containment.

**Patented\* Clean-Sweep™ air foil** allows air to sweep the work surface to maximize containment.

**Safety-First Vapor Sensor** accurately detects filter break through. Primary and secondary backup sensors provide redundant monitoring and detection of organic solvents, smoke particulates, ammonia gases, formaldehyde gases and hydro-sulfide gases. The sensor also provides an early warning when 5-10% of filter life is remaining to allow time for the user to change filters. See page 8 for details.

**Durable powder-coated aluminum frame, steel rear baffle and plenum** provide chemical resistance and robust construction. No unreliable plastic-to-plastic bonding is used.

**Quieter, cooler and more energy-efficient ECM impeller** is 95% efficient, generates less heat for more comfortable working conditions, and operates from 52 to 62 dBA at 80 fpm depending on model.

**Smart-Flow™ System** adjusts the motor speed automatically for filter pressure drop, barometric pressure and room temperature, and maintains constant airflow at the calibrated value.

**Accommodates seven filter types** to cover a wide variety of needs. Filters are stackable to handle mixed chemical applications.

**Large LCD** displays face velocity and filter status, and touchpad control of enclosure operation. Filter life and check timers trigger audible/visual alert messages after the specified number of hours has elapsed.

**Two utility ports** allow passage of tubing, electrical cords and interface cables from inside to back exterior for connection to services.

**Ergonomic angled sash and patented\*\* sloped front** allow a closer view of the work area, reduce glare and provide a more comfortable operating position. Hinged sash pivots upward for loading and has a wiping seal to contain contaminants. Larger models incorporate an external gas-assist lift.

**Spacious sash opening** provides comfortable access to the work area. Opening spans the width of the enclosure and is 9.4" (23.9 cm) or 12.0" (48.3 cm) high depending on the model.



**Patented\* rear baffle** with zones of perforations promotes non-turbulent horizontal laminar airflow. The baffle pivots down for cleaning.

**Optional clear safety glass baffle** provides 360° visibility for teaching demonstrations. The baffle pivots down for cleaning.

**Durable tempered safety glass front sash and sides** provide visibility, ambient light and chemical resistance. Glass does not easily discolor or craze like plastic can.



**Convenient, front-accessible filter replacement.** The gas spring-assisted clamping mechanism opens effortlessly and applies uniform pressure across the top surface of the filters for leak-proof, one-step filter replacement.



Intertek

Exclusive feature

\*U.S. Patent No. 6,461,233

\*\*U.S. Patent No. D 538,941



# Paramount® Ductless Enclosures



- ▶ Smart-Flow™ system to automatically adjust motor speed for filter pressure drop, barometric pressure and room temperature.
- ▶ LCD message center, 3" x 1.5", to provide continuous status reports for each filter, airflow speed, and filter saturation and low airflow alarm messages.
- ▶ Filter life and check timers with audible/LCD visual elapsed time alerts.
- ▶ Digital touchpad controls.
- ▶ Powder-coated aluminum frame and steel rear plenum and baffle. No plastic-to-plastic bonding is used.
- ▶ Pre-wired fluorescent lamp with timer.
- ▶ Electronic security lock (optional activation) that requires password to change operating parameters.
- ▶ 1/4" thick tempered safety glass front sash and sides.
- ▶ Ergonomic angled and hinged pivoting sash with wiping seal and patented\*\* sloped front.
- ▶ Models with 9.4" sash opening height have 16.5" locking height and 19.0" maximum loading height. Models with 12.0" sash opening height and 32.0" interior height have 25.8" locking height and 28.3" maximum loading height. Models with 12.0" sash opening height and 35.0" interior height have 28.8" locking height and 31.3" maximum loading height.
- ▶ Filter efficiency performance independently verified by University of Kansas.
- ▶ Particulate containment data independently confirmed by SafeBridge+ Consultants, Inc.
- ▶ 8.2' power cord and plug. No plug on 230 volt models.
- ▶ ETL+ listed (115 volt models).



Above: 4' Paramount Ductless Enclosure 6963401 is shown with Work Surface 3909902 and Protector Standard Base Cabinet 9900000. Work Surface, Base Cabinet and filters are sold separately. At left: Three screens alternate on the LCD display: filter types and status, estimated filter life for the bottom filter(s), and estimated filter life for the top filter(s). All three screens display face velocity.

## All models conform to the following regulations and standards:

- ▶ SEFA+ 9-2010, DH II
- ▶ SEFA+ 8-2010, Cabinet Surface Finish Tests
- ▶ ASHRAE+ 110-95
- ▶ ANSI+ Z9.5-2011
- ▶ UL+ 61010-1
- ▶ CAN/CSA+ C22.2 No. 61010-1
- ▶ CE+ Conformity Marking (230 volt models)

## Models with glass baffle feature:

- ▶ 1/4" thick tempered safety glass baffle without perforations that pivots down for cleaning.

## All models require (not included):

- ▶ Work Surface and Base. See page 9. Contact Labconco for stand and cabinet options.
- ▶ Filters. See page 8.

## Optional accessories:

- ▶ Canopy Exhaust Transition. See page 9.
- ▶ Sash Closures. See page 9.
- ▶ Utility Shelves, Bottle Holder and Tissue Holder. See page 23.

## All models feature:

- ▶ Clean-Sweep air foil.\*
- ▶ Upper dilution air supply.
- ▶ Upper containment sash foil.
- ▶ Zone-perforated rear baffle that pivots down for cleaning.\*
- ▶ Side-entry air foils.
- ▶ Safety-First™ vapor sensor with early audible warning for accurate detection of filter break through.
- ▶ ECM impeller with timer that operates at 52-62 dBA at 80 feet per minute. 6' Paramounts have two impellers.

**Contact Labconco at 800-821-5525 or 816-333-8811 for application assistance.**

\*Exclusive feature \*\*U.S. Patent No. 6,461,233 \*\*U.S. Patent No. D 538,941  
 †See page 26 for a list of regulations, standards and registered trademarks.



# Ordering Information

PARAMOUNT® DUCTLESS ENCLOSURES

| Nominal Width | Catalog (Description)                | Electrical Requirements | Overall W x D x H         | Internal Working Height | Sash Opening Working Height | Sash Opening Loading Height* | Face Velocity (fpm) | Airflow Exhaust Volume (CFM) | Noise Pressure (dba) | Shipping Weight (lbs./kg) |
|---------------|--------------------------------------|-------------------------|---------------------------|-------------------------|-----------------------------|------------------------------|---------------------|------------------------------|----------------------|---------------------------|
| 2'            | <b>6963200</b><br>(Std.)             | 115 volts, 50/60 Hz     | 24.0" x 29.0" x 43.7"     | 22.7"                   | 9.4"                        | 19.0"                        | 60                  | 85                           | 50                   | 175/79                    |
|               |                                      |                         | (61.0 x 73.7 x 111.0 cm)  | (57.7 cm)               | (23.9 cm)                   | (48.3 cm)                    | 80                  | 115                          | 54                   |                           |
|               |                                      |                         |                           |                         |                             | 100                          | 145                 | 59                           |                      |                           |
| 2'            | <b>6963220**</b><br>(Std.)           | 230 volts, 50/60 Hz     | 24.0" x 29.0" x 43.7"     | 22.7"                   | 9.4"                        | 19.0"                        | 60                  | 85                           | 50                   | 175/79                    |
|               |                                      |                         | (61.0 x 73.7 x 111.0 cm)  | (57.7 cm)               | (23.9 cm)                   | (48.3 cm)                    | 80                  | 115                          | 54                   |                           |
|               |                                      |                         |                           |                         |                             | 100                          | 145                 | 59                           |                      |                           |
| 3'            | <b>6963300</b><br>(Std.)             | 115 volts, 50/60 Hz     | 36.0" x 29.0" x 43.7"     | 22.7"                   | 9.4"                        | 19.0"                        | 60                  | 130                          | 46                   | 225/102                   |
|               |                                      |                         | (91.4 x 73.7 x 111.0 cm)  | (57.7 cm)               | (23.9 cm)                   | (48.3 cm)                    | 80                  | 175                          | 52                   |                           |
|               |                                      |                         |                           |                         |                             | 100                          | 220                 | 56                           |                      |                           |
| 3'            | <b>6963301</b><br>(Tall)             | 115 volts, 50/60 Hz     | 36.0" x 29.0" x 53.0"     | 32.0"                   | 12.0"                       | 28.3"                        | 60                  | 170                          | 52                   | 255/116                   |
|               |                                      |                         | (91.4 x 73.7 x 134.6 cm)  | (81.3 cm)               | (30.5 cm)                   | (71.8 cm)                    | 80                  | 230                          | 57                   |                           |
|               |                                      |                         |                           |                         |                             | 100                          | 285                 | 62                           |                      |                           |
| 3'            | <b>6963302†</b><br>(Tall & Clear)    | 115 volts, 50/60 Hz     | 36.0" x 29.0" x 53.0"     | 32.0"                   | 12.0"                       | 28.3"                        | 60                  | 170                          | 52                   | 275/125                   |
|               |                                      |                         | (91.4 x 73.7 x 134.6 cm)  | (81.3 cm)               | (30.5 cm)                   | (71.8 cm)                    | 80                  | 230                          | 57                   |                           |
|               |                                      |                         |                           |                         |                             | 100                          | 285                 | 62                           |                      |                           |
| 3'            | <b>6963320**</b><br>(Std.)           | 230 volts, 50/60 Hz     | 36.0" x 29.0" x 43.7"     | 22.7"                   | 9.4"                        | 19.0"                        | 60                  | 130                          | 46                   | 225/102                   |
|               |                                      |                         | (91.4 x 73.7 x 111.0 cm)  | (57.7 cm)               | (23.9 cm)                   | (48.3 cm)                    | 80                  | 175                          | 52                   |                           |
|               |                                      |                         |                           |                         |                             | 100                          | 220                 | 56                           |                      |                           |
| 3'            | <b>6963321**</b><br>(Tall)           | 230 volts, 50/60 Hz     | 36.0" x 29.0" x 53.0"     | 32.0"                   | 12.0"                       | 28.3"                        | 60                  | 170                          | 52                   | 255/116                   |
|               |                                      |                         | (91.4 x 73.7 x 134.6 cm)  | (81.3 cm)               | (30.5 cm)                   | (71.8 cm)                    | 80                  | 230                          | 57                   |                           |
|               |                                      |                         |                           |                         |                             | 100                          | 285                 | 62                           |                      |                           |
| 3'            | <b>6963322***†</b><br>(Tall & Clear) | 230 volts, 50/60 Hz     | 36.0" x 29.0" x 53.0"     | 32.0"                   | 12.0"                       | 28.3"                        | 60                  | 170                          | 52                   | 275/125                   |
|               |                                      |                         | (91.4 x 73.7 x 134.6 cm)  | (81.3 cm)               | (30.5 cm)                   | (71.8 cm)                    | 80                  | 230                          | 57                   |                           |
|               |                                      |                         |                           |                         |                             | 100                          | 285                 | 62                           |                      |                           |
| 4'            | <b>6963400</b><br>(Std.)             | 115 volts, 50/60 Hz     | 48.0" x 29.0" x 43.7"     | 22.7"                   | 9.4"                        | 19.0"                        | 60                  | 175                          | 53                   | 275/125                   |
|               |                                      |                         | (121.9 x 73.7 x 111.0 cm) | (57.7 cm)               | (23.9 cm)                   | (48.3 cm)                    | 80                  | 235                          | 57                   |                           |
|               |                                      |                         |                           |                         |                             | 100                          | 295                 | 62                           |                      |                           |
| 4'            | <b>6963401</b><br>(Tall)             | 115 volts, 50/60 Hz     | 48.0" x 29.0" x 53.0"     | 32.0"                   | 12.0"                       | 28.3"                        | 60                  | 230                          | 57                   | 315/143                   |
|               |                                      |                         | (121.9 x 73.7 x 134.6 cm) | (81.3 cm)               | (30.5 cm)                   | (71.8 cm)                    | 80                  | 305                          | 62                   |                           |
|               |                                      |                         |                           |                         |                             | 100                          | 380                 | 67                           |                      |                           |
| 4'            | <b>6963402†</b><br>(Tall & Clear)    | 115 volts, 50/60 Hz     | 48.0" x 29.0" x 53.0"     | 32.0"                   | 12.0"                       | 28.3"                        | 60                  | 230                          | 57                   | 345/156                   |
|               |                                      |                         | (121.9 x 73.7 x 134.6 cm) | (81.3 cm)               | (30.5 cm)                   | (71.8 cm)                    | 80                  | 305                          | 62                   |                           |
|               |                                      |                         |                           |                         |                             | 100                          | 380                 | 67                           |                      |                           |
| 4'            | <b>6963403</b><br>(Tall & Deep)      | 115 volts, 50/60 Hz     | 48.0" x 35.5" x 56.0"     | 35.0"                   | 12.0"                       | 31.3"                        | 60                  | 230                          | 59                   | 540/245                   |
|               |                                      |                         | (121.9 x 90.2 x 142.2 cm) | (88.9 cm)               | (30.5 cm)                   | (79.4 cm)                    | 80                  | 305                          | 62                   |                           |
|               |                                      |                         |                           |                         |                             | 100                          | 380                 | 67                           |                      |                           |
| 4'            | <b>6963420**</b><br>(Std.)           | 230 volts, 50/60 Hz     | 48.0" x 29.0" x 43.7"     | 22.7"                   | 9.4"                        | 19.0"                        | 60                  | 175                          | 53                   | 275/125                   |
|               |                                      |                         | (121.9 x 73.7 x 111.0 cm) | (57.7 cm)               | (23.9 cm)                   | (48.3 cm)                    | 80                  | 235                          | 57                   |                           |
|               |                                      |                         |                           |                         |                             | 100                          | 295                 | 62                           |                      |                           |
| 4'            | <b>6963421**</b><br>(Tall)           | 230 volts, 50/60 Hz     | 48.0" x 29.0" x 53.0"     | 32.0"                   | 12.0"                       | 28.3"                        | 60                  | 230                          | 57                   | 315/143                   |
|               |                                      |                         | (121.9 x 73.7 x 134.6 cm) | (81.3 cm)               | (30.5 cm)                   | (71.8 cm)                    | 80                  | 305                          | 62                   |                           |
|               |                                      |                         |                           |                         |                             | 100                          | 380                 | 67                           |                      |                           |
| 4'            | <b>6963422***†</b><br>(Tall & Clear) | 230 volts, 50/60 Hz     | 48.0" x 29.0" x 53.0"     | 32.0"                   | 12.0"                       | 28.3"                        | 60                  | 230                          | 57                   | 345/156                   |
|               |                                      |                         | (121.9 x 73.7 x 134.6 cm) | (81.3 cm)               | (30.5 cm)                   | (71.8 cm)                    | 80                  | 305                          | 62                   |                           |
|               |                                      |                         |                           |                         |                             | 100                          | 380                 | 67                           |                      |                           |
| 4'            | <b>6963423**</b><br>(Tall & Deep)    | 230 volts, 50/60 Hz     | 48.0" x 35.5" x 56.0"     | 35.0"                   | 12.0"                       | 31.3"                        | 60                  | 230                          | 59                   | 540/245                   |
|               |                                      |                         | (121.9 x 90.2 x 142.2 cm) | (88.9 cm)               | (30.5 cm)                   | (79.4 cm)                    | 80                  | 305                          | 62                   |                           |
|               |                                      |                         |                           |                         |                             | 100                          | 380                 | 67                           |                      |                           |
| 5'            | <b>6963501</b><br>(Tall)             | 115 volts, 50/60 Hz     | 60.0" x 29.0" x 53.0"     | 32.0"                   | 9.4"                        | 28.3"                        | 60                  | 220                          | 57                   | 395/179                   |
|               |                                      |                         | (152.4 x 73.7 x 134.6 cm) | (81.3 cm)               | (23.9 cm)                   | (71.8 cm)                    | 80                  | 295                          | 62                   |                           |
|               |                                      |                         |                           |                         |                             | 100                          | 370                 | 67                           |                      |                           |
| 5'            | <b>6963503</b><br>(Tall & Deep)      | 115 volts, 50/60 Hz     | 60.0" x 35.5" x 56.0"     | 35.0"                   | 9.4"                        | 31.3"                        | 60                  | 220                          | 57                   | 565/256                   |
|               |                                      |                         | (152.4 x 90.2 x 142.2 cm) | (88.9 cm)               | (23.9 cm)                   | (79.4 cm)                    | 80                  | 295                          | 62                   |                           |
|               |                                      |                         |                           |                         |                             | 100                          | 370                 | 67                           |                      |                           |
| 5'            | <b>6963521**</b><br>(Tall)           | 230 volts, 50/60 Hz     | 60.0" x 29.0" x 53.0"     | 32.0"                   | 9.4"                        | 28.3"                        | 60                  | 220                          | 57                   | 395/179                   |
|               |                                      |                         | (152.4 x 73.7 x 134.6 cm) | (81.3 cm)               | (23.9 cm)                   | (71.8 cm)                    | 80                  | 295                          | 62                   |                           |
|               |                                      |                         |                           |                         |                             | 100                          | 370                 | 67                           |                      |                           |
| 5'            | <b>6963523**</b><br>(Tall & Deep)    | 230 volts, 50/60 Hz     | 60.0" x 35.5" x 56.0"     | 35.0"                   | 9.4"                        | 31.3"                        | 60                  | 220                          | 57                   | 565/256                   |
|               |                                      |                         | (152.4 x 90.2 x 142.2 cm) | (88.9 cm)               | (23.9 cm)                   | (79.4 cm)                    | 80                  | 295                          | 62                   |                           |
|               |                                      |                         |                           |                         |                             | 100                          | 370                 | 67                           |                      |                           |
| 6'            | <b>6963601</b><br>(Tall)             | 115 volts, 50/60 Hz     | 72.0" x 29.0" x 53.0"     | 32.0"                   | 12.0"                       | 28.3"                        | 60                  | 350                          | 57                   | 475/215                   |
|               |                                      |                         | (182.9 x 73.7 x 134.6 cm) | (81.3 cm)               | (30.5 cm)                   | (71.8 cm)                    | 80                  | 465                          | 61                   |                           |
|               |                                      |                         |                           |                         |                             | 100                          | 580                 | 66                           |                      |                           |
| 6'            | <b>6963603</b><br>(Tall & Deep)      | 115 volts, 50/60 Hz     | 72.0" x 35.5" x 56.0"     | 35.0"                   | 12.0"                       | 31.3"                        | 60                  | 350                          | 57                   | 680/308                   |
|               |                                      |                         | (182.9 x 90.2 x 142.2 cm) | (88.9 cm)               | (30.5 cm)                   | (79.4 cm)                    | 80                  | 465                          | 61                   |                           |
|               |                                      |                         |                           |                         |                             | 100                          | 580                 | 66                           |                      |                           |
| 6'            | <b>6963621**</b><br>(Tall)           | 230 volts, 50/60 Hz     | 72.0" x 29.0" x 53.0"     | 32.0"                   | 12.0"                       | 28.3"                        | 60                  | 350                          | 57                   | 475/215                   |
|               |                                      |                         | (182.9 x 73.7 x 134.6 cm) | (81.3 cm)               | (30.5 cm)                   | (71.8 cm)                    | 80                  | 465                          | 61                   |                           |
|               |                                      |                         |                           |                         |                             | 100                          | 580                 | 66                           |                      |                           |
| 6'            | <b>6963623**</b><br>(Tall & Deep)    | 230 volts, 50/60 Hz     | 72.0" x 35.5" x 56.0"     | 35.0"                   | 12.0"                       | 31.3"                        | 60                  | 350                          | 57                   | 680/308                   |
|               |                                      |                         | (182.9 x 90.2 x 142.2 cm) | (88.9 cm)               | (30.5 cm)                   | (79.4 cm)                    | 80                  | 465                          | 61                   |                           |
|               |                                      |                         |                           |                         |                             | 100                          | 580                 | 66                           |                      |                           |

\*Locking height is 2.5" (6.4 cm) less than the loading height.

\*\* International electrical configuration

†360° visibility with glass rear wall and baffle



# Ordering Information

PARAMOUNT® DUCTLESS ENCLOSURES

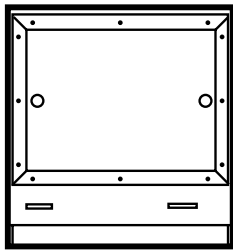

TOP

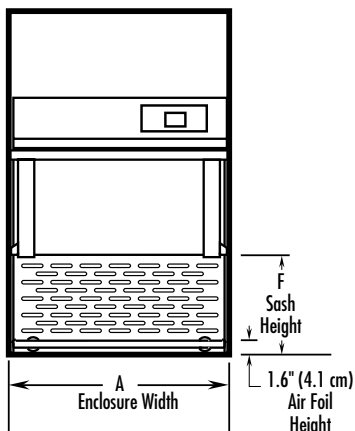

FRONT

| Catalog Numbers    | Paramount Description     | Overall Width A     | Interior Height B  | Interior Depth C   | Exterior Depth D   | Exterior Height E   | Sash Opening F     |
|--------------------|---------------------------|---------------------|--------------------|--------------------|--------------------|---------------------|--------------------|
| 6963200<br>6963220 | 2' Standard               | 24.0"<br>(61.0 cm)  | 22.7"<br>(57.7 cm) | 23.4"<br>(59.4 cm) | 29.0"<br>(73.7 cm) | 43.7"<br>(111.0 cm) | 9.4"<br>(23.9 cm)  |
| 6963300<br>6963320 | 3' Standard               | 36.0"<br>(91.4 cm)  | 22.7"<br>(57.7 cm) | 23.4"<br>(59.4 cm) | 29.0"<br>(73.7 cm) | 43.7"<br>(111.0 cm) | 9.4"<br>(23.9 cm)  |
| 6963301<br>6963321 | 3' Tall                   | 36.0"<br>(91.4 cm)  | 32.0"<br>(81.3 cm) | 23.4"<br>(59.4 cm) | 29.0"<br>(73.7 cm) | 53.0"<br>(134.6 cm) | 12.0"<br>(30.5 cm) |
| 6963302<br>6963322 | 3' Tall with Clear Baffle | 36.0"<br>(91.4 cm)  | 32.0"<br>(81.3 cm) | 23.4"<br>(59.4 cm) | 29.0"<br>(73.7 cm) | 53.0"<br>(134.6 cm) | 12.0"<br>(30.5 cm) |
| 6963400<br>6963420 | 4' Standard               | 48.0"<br>(121.9 cm) | 22.7"<br>(57.7 cm) | 23.4"<br>(59.4 cm) | 29.0"<br>(73.7 cm) | 43.7"<br>(111.0 cm) | 9.4"<br>(23.9 cm)  |
| 6963401<br>6963421 | 4' Tall                   | 48.0"<br>(121.9 cm) | 32.0"<br>(81.3 cm) | 23.4"<br>(59.4 cm) | 29.0"<br>(73.7 cm) | 53.0"<br>(134.6 cm) | 12.0"<br>(30.5 cm) |
| 6963402<br>6963422 | 4' Tall with Clear Baffle | 48.0"<br>(121.9 cm) | 32.0"<br>(81.3 cm) | 23.4"<br>(59.4 cm) | 29.0"<br>(73.7 cm) | 53.0"<br>(134.6 cm) | 12.0"<br>(30.5 cm) |
| 6963403<br>6963423 | 4' Tall & Deep            | 48.0"<br>(121.9 cm) | 35.0"<br>(88.9 cm) | 30.0"<br>(76.2 cm) | 35.5"<br>(90.2 cm) | 56.0"<br>(142.2 cm) | 12.0"<br>(30.5 cm) |
| 6963501<br>6963521 | 5' Tall                   | 60.0"<br>(152.4 cm) | 32.0"<br>(81.3 cm) | 23.4"<br>(59.4 cm) | 29.0"<br>(73.7 cm) | 53.0"<br>(134.6 cm) | 9.4"<br>(23.9 cm)  |
| 6963503<br>6963523 | 5' Tall & Deep            | 60.0"<br>(152.4 cm) | 35.0"<br>(88.9 cm) | 30.0"<br>(76.2 cm) | 35.5"<br>(90.2 cm) | 56.0"<br>(142.2 cm) | 9.4"<br>(23.9 cm)  |
| 6963601<br>6963621 | 6' Tall                   | 72.0"<br>(182.9 cm) | 32.0"<br>(81.3 cm) | 23.4"<br>(59.4 cm) | 29.0"<br>(73.7 cm) | 53.0"<br>(134.6 cm) | 12.0"<br>(30.5 cm) |
| 6963603<br>6963623 | 6' Tall & Deep            | 72.0"<br>(182.9 cm) | 35.0"<br>(88.9 cm) | 30.0"<br>(76.2 cm) | 35.5"<br>(90.2 cm) | 56.0"<br>(142.2 cm) | 12.0"<br>(30.5 cm) |

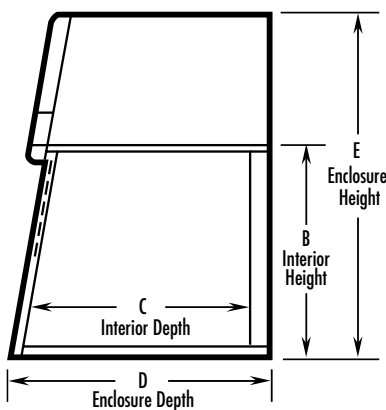

SIDE  
(Standard Models)

6963200, 6963220,  
6963300, 6963320,  
6963400, 6963420

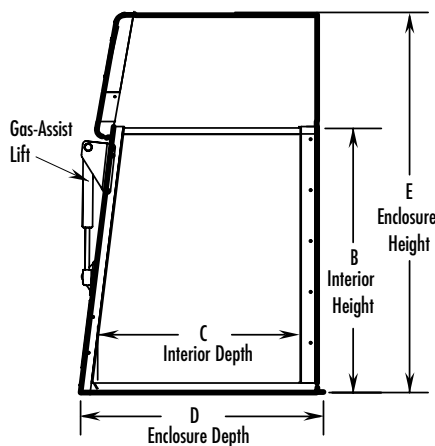

SIDE  
(Tall Models)

6963301, 6963302,  
6963321, 6963322,  
6963401, 6963402,  
6963421, 6963422,  
6963501, 6963521,  
6963601, 6963621

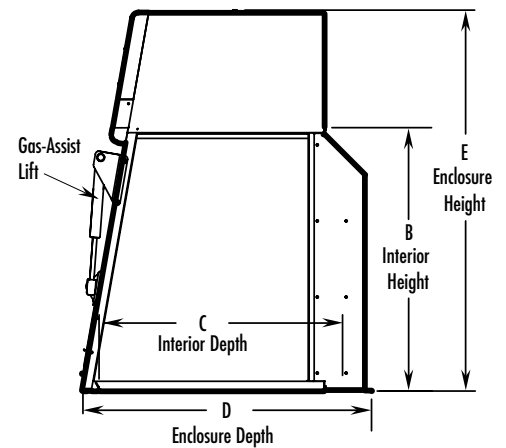

SIDE  
(Tall & Deep Models)

6963403, 6963423,  
6963503, 6963523,  
6963603, 6963623



# Safety-First™ Vapor Sensor Details

PARAMOUNT® DUCTLESS ENCLOSURES

The Safety-First™ Organic Vapor sensor detects contaminants in the exhaust indicating break through and has a sensitivity range of 0.1-30 ppm. Typical chemicals detected by the sensor are indicated in the chart below.

## Chemical Sensitivity Alert Concentrations

| Chemical Family                   | Chemical                              | Sensitivity Alert Concentration             | Odor Threshold (ppm) | Exposure Limit TWA* (ppm) | Filter Capacity† (% W) | Filter Type     |
|-----------------------------------|---------------------------------------|---|----------------------|---------------------------|------------------------|-----------------|
| Aldehydes & Ketones               | Cyclohexanone                         | 0.2-0.5 ppm                                 | 0.068                | 50                        | 22%                    | OV              |
| Mixture of Aliphatic Hydrocarbons | Gasoline                              | 0.3-1.0 ppm                                 | 0.3                  | 300                       | 11%                    | OV              |
| Particulates                      | Cigarette smoke                       | 0.4-1.0 ppm                                 | N/A                  | N/A                       | N/A                    | OV & HEPA       |
| Aldehydes & Ketones               | Acetone                               | 0.5-1.0 ppm                                 | 4.58                 | 250                       | 2%                     | OV              |
| Aromatic Hydrocarbons             | Toluene                               | 0.5-1.0 ppm                                 | 0.16                 | 100                       | 20%                    | OV              |
| Ethers                            | Methyl Tert-Butyl Ether               | 0.5-1.0 ppm                                 | 0.053                | 50                        | 9%                     | OV              |
| Sulfur Compounds                  | Hydrogen Sulfide                      | 0.5-2.0 ppm                                 | 0.0005               | 10                        | 10%                    | AG              |
| Nitrogen Compounds                | Diethylamine                          | 1.5-2.0 ppm                                 | 0.186                | 10                        | 7%                     | OV              |
| Esters                            | Ethyl Acetate                         | 1.5-4 ppm                                   | 0.61                 | 400                       | 9%                     | OV              |
| Ethers                            | Diethyl Ether                         | 2-4 ppm                                     | 2.29                 | 400                       | 4%                     | OV              |
| Aldehydes                         | Formaldehyde                          | 2-4 ppm, best to use other detector methods | 0.87                 | 0.1 ceiling, 0.016        | 10%                    | FORM            |
| Nitrogen Compounds                | Ammonia Solution (Ammonium Hydroxide) | 2-5 ppm                                     | 5.75                 | 25                        | 10%                    | AM              |
| Alcohols                          | Ethyl Alcohol**                       | 2.5-6 ppm                                   | 0.136                | 1000                      | 1.3%                   | OV              |
| Acids                             | Acetic Acid                           | 5-6 ppm                                     | 0.016                | 10                        | 4%                     | OV              |
| Halogens                          | Chlorobenzene                         | 5-8 ppm                                     | 0.741                | 10                        | 20%                    | OV              |
| Alcohols                          | Isopropyl Alcohol                     | 8-11 ppm                                    | 22                   | 200                       | 7%                     | OV              |
| Aliphatic Hydrocarbons            | Hexane                                | 9-15 ppm                                    | 21.9                 | 50                        | 11%                    | OV              |
| Alcohols                          | Methanol**                            | 15-25 ppm                                   | 141                  | 200                       | 0.1%, very low         | not recommended |
| Mineral Acids                     | Hydrochloric Acid                     | Not detected.††<br>Use other means.         | 0.77                 | 5                         | 17%                    | AG              |

\*Time-weighted average recommended by NIOSH

†Based on 10 ppm inlet concentration

\*\*Important Note: Clean up procedures using alcohols or volatile chemicals with low filter capacity could saturate the filters quickly. †† Important Note: The vapor sensor does not detect mineral acid gases such as hydrochloric acid, nitric acid, or sulfuric acid. Other detector means such as a mineral acid sensor or interval timed sampling with sampling tubes must be used. The chart is only a guideline. Frequent chemical testing or filter monitoring is recommended. If chemical suitability is ever in question, always work below the acceptable exposure limit/TWA to maximize both safety and filter performance.

OV=Organic Vapors, AG=Acid-Sulfur Gases, FORM=Formaldehyde, AM=Ammonia-Amine

## Filters & Accessories

PARAMOUNT® DUCTLESS ENCLOSURES



The Application Matrix on page 3 provides examples of appropriate uses for Paramount Carbon and HEPA Filters. Filters are available in seven different types and any two types of filters may be stacked to handle mixed chemical applications. Before selecting a Paramount Ductless Enclosure or any Labconco carbon-filtered enclosure, please complete the online **Chemical Assessment** form available at [www.labconco.com](http://www.labconco.com) or contact Labconco at 816-333-8811 or 800-821-5525. A Labconco specialist will review your application and chemical usage and recommend the enclosure and filters right for you.

### Paramount Filters

Contain porous, coconut shell carbon for maximum adsorption. Roughing prefilters are adhered to both sides of each filter to remove dust and other particles. All impregnated carbon filters contain 25% activated carbon by weight.

| Paramount Width | No. of Filters Required (not included)* | Total Organic Vapor Filter Weight |
|-----------------|---|-----------------------------------|
| 2'              | 2                                       | 15 lbs. (6.8 kg)                  |
| 3'              | 4                                       | 30 lbs. (13.6 kg)                 |
| 4'              | 6                                       | 45 lbs. (20.4 kg)                 |
| 5'              | 6                                       | 45 lbs. (20.4 kg)                 |
| 6'              | 8                                       | 60 lbs. (27.2 kg)                 |

\*Labconco strongly recommends ordering and keeping an extra set of filters to have readily available when filters become saturated and require replacement.

| Catalog Number | Filter Description  | Shipping Weight (lbs./kg) |
|----------------|---|---------------------------|
| 6938100        | HEPA, 99.99% efficient particulate  | 9.0/4.0                   |
| 6938200        | Activated Carbon, Organic Vapor, 7.5 lbs.   | 12.5/5.7                  |
| 6938201        | Impregnated Carbon, Acid-Sulfur, 10 lbs.  | 15.0/6.8                  |
| 6938202        | Impregnated Carbon, Ammonia-Amine, 11 lbs.  | 16.0/7.3                  |
| 6938203        | Impregnated Carbon, Formaldehyde, 10 lbs.   | 15.0/6.8                  |
| 6938204        | Mixed Bed Carbon, 10 lbs.<br>Contains approximately 43% Activated Carbon (Organic Vapor), 19% Acid-Sulfur, 19% Ammonia-Amine and 19% Formaldehyde by weight | 15.0/6.8                  |
| 6938205        | Impregnated Carbon, Radioisotope, 10 lbs.   | 15.0/6.8                  |

### Filter Accessories

| Catalog Number | Description  | Shipping Weight (lbs./kg) |
|----------------|--|---------------------------|
| 6924900        | Syringe Kit for carbon filter saturation detection | 1.0/0.5                   |
| 6925700        | Ammonia Detector Tubes, package of 3               | 0.5/0.2                   |
| 6925800        | Acid Gas Detector Tubes, package of 3              | 0.5/0.2                   |
| 6926000        | Formaldehyde Detector Tubes, package of 3          | 0.5/0.2                   |





## Accessories

PARAMOUNT® DUCTLESS ENCLOSURES



### Black Solid Epoxy Work Surfaces

Chemical-resistant, black solid epoxy work surfaces, offered in 2', 3', 4', 5' and 6' widths, are dished to contain spills and contoured to fit the dimensions of Paramount Ductless Enclosures. 1.0" (2.5 cm) thick.

| Catalog # | Nominal Width | For use with:   | Dimensions (w x d)              | Ship. Wt. (lbs./kg) |
|-----------|---------------|-----------------|---------------------------------|---------------------|
| 3909900   | 2'            | Paramount       | 24.0" x 29.0" (61.0 x 73.7 cm)  | 50/23               |
| 3909901   | 3'            | Paramount       | 36.0" x 29.0" (91.4 x 73.7 cm)  | 75/34               |
| 3909902   | 4'            | Paramount       | 48.0" x 29.0" (121.9 x 73.7 cm) | 100/45              |
| 3909906   | 4'            | Paramount, Deep | 48.0" x 35.5" (121.9 x 90.2 cm) | 125/56              |
| 3909907   | 5'            | Paramount       | 60.0" x 29.0" (152.4 x 73.7 cm) | 125/56              |
| 3909908   | 5'            | Paramount, Deep | 60.0" x 35.5" (152.4 x 90.2 cm) | 155/70              |
| 3909910   | 6'            | Paramount       | 72.0" x 29.0" (182.9 x 73.7 cm) | 150/68              |
| 3909911   | 6'            | Paramount, Deep | 72.0" x 35.5" (182.0 x 90.2 cm) | 186/84              |



### Stainless Steel Work Surfaces

Type 304 stainless steel work surfaces, offered in 4', 5' and 6' widths, include a 0.8" (2.0 cm) deep front trough to contain spills. 0.8" (2.0 cm) thick.

| Catalog # | Nominal Width | For use with:   | Dimensions (w x d)              | Ship. Wt. (lbs./kg) |
|-----------|---------------|-----------------|---------------------------------|---------------------|
| 3975504   | 4'            | Paramount, Deep | 48.0" x 35.5" (121.9 x 90.2 cm) | 145/65              |
| 3975502   | 5'            | Paramount       | 60.0" x 29.0" (152.4 x 73.7 cm) | 150/68              |
| 3975503   | 5'            | Paramount, Deep | 60.0" x 35.5" (152.4 x 90.2 cm) | 180/82              |
| 3975602   | 6'            | Paramount       | 72.0" x 29.0" (182.9 x 73.7 cm) | 180/82              |
| 3975603   | 6'            | Paramount, Deep | 72.0" x 35.5" (182.0 x 90.2 cm) | 220/100             |

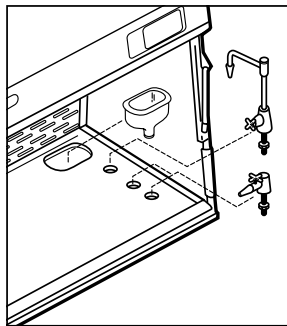

### Work Surfaces with Deck-Mounted Service Fixtures

These chemical-resistant, black solid epoxy work surfaces, offered in 3', 4', 5' and 6' widths, are dished to contain spills and contoured to fit the dimensions of Paramount Ductless Enclosures. Pre-drilled holes allow installation of two deck-mounted service fixtures with hose barbs for plumbing to water, air and vacuum; a 3" x 6" cupsink; and a gooseneck faucet with vacuum breaker. Two standard chrome-plated service fixtures with turrets, hose barbs, brass valves and 3/8" NPS pipe connections; a 3" x 6" polypropylene oval cupsink; and a brass cold water faucet with swivel/ rigid gooseneck, brass valve and 1/4" NPS pipe connection are included. 29.0" (73.7 cm) x 1.0" (2.5 cm) thick.

These chemical-resistant, black solid epoxy work surfaces, offered in 3', 4', 5' and 6' widths, are dished to contain spills and contoured to fit the dimensions of Paramount Ductless Enclosures. Pre-drilled holes allow installation of two deck-mounted service fixtures with hose barbs for plumbing to water, air and vacuum; a 3" x 6" cupsink; and a gooseneck faucet with vacuum breaker. Two standard chrome-plated service fixtures with turrets, hose barbs, brass valves and 3/8" NPS pipe connections; a 3" x 6" polypropylene oval cupsink; and a brass cold water faucet with swivel/ rigid gooseneck, brass valve and 1/4" NPS pipe connection are included. 29.0" (73.7 cm) x 1.0" (2.5 cm) thick.

| Catalog # | Nominal Width | For use with: | Actual Width     | Ship. Wt. (lbs./kg) |
|-----------|---------------|---------------|------------------|---------------------|
| 6963800   | 3'            | Paramount     | 36.0" (91.4 cm)  | 85/38               |
| 6963801   | 4'            | Paramount     | 48.0" (121.9 cm) | 110/50              |
| 6963802   | 5'            | Paramount     | 60.0" (152.4 cm) | 135/61              |
| 6963803   | 6'            | Paramount     | 72.0" (182.9 cm) | 160/72              |



Solo Hydraulic Lift Base Stand 3780311

### SoLo™ Hydraulic Lift Base Stands

Allow Paramount transport through standard doorways. For example, Paramount 6963403 mounted atop Work Surface 3909906 may be lowered to 71.2". Powder-coated steel. Remote-control operated hydraulic lift provides infinitely adjustable work surface heights from 15.2" to 34.8" high. Depth is 34.3". Toe-locking casters, 5" diameter, with bearings. **Work surface is required.**

| Catalog # | Nominal Width | Actual Width     | Electrical Requirements  | Ship. Wt. (lbs./kg) |
|-----------|---------------|------------------|--------------------------|---------------------|
| 3780310   | 3'            | 53.5" (135.9 cm) | 115 volts, 60 Hz, 2 amps | 395/179             |
| 3780314*  | 3'            | 53.5" (135.9 cm) | 230 volts, 50 Hz, 3 amps | 395/179             |
| 3780311   | 4'            | 65.5" (166.4 cm) | 115 volts, 60 Hz, 2 amps | 435/197             |
| 3780315*  | 4'            | 65.5" (166.4 cm) | 230 volts, 50 Hz, 3 amps | 435/197             |
| 3780312   | 5'            | 77.5" (196.9 cm) | 115 volts, 60 Hz, 2 amps | 460/209             |
| 3780316*  | 5'            | 77.5" (196.9 cm) | 230 volts, 50 Hz, 3 amps | 460/209             |
| 3780313   | 6'            | 89.5" (227.3 cm) | 115 volts, 60 Hz, 2 amps | 600/272             |
| 3780317*  | 6'            | 89.5" (227.3 cm) | 230 volts, 50 Hz, 3 amps | 600/272             |

Comply with height and knee clearance guidelines outlined in Americans with Disabilities Act (ADA) Standards for Accessible Design. \*International electrical configuration

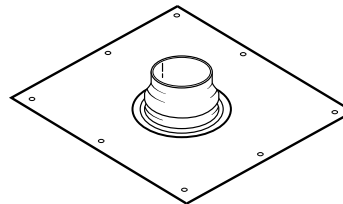

### 6963700 Canopy Exhaust Transition

Allows the Paramount Ductless Enclosure to be thimble-ducted to the outside for additional protection. The canopy's air gap provides a means of balancing air by allowing room air to enter the duct-

work and mix with the filtered air being exhausted from the Paramount. House exhaust or remote blower and ductwork are required (not included). 6" (15 cm) diameter outlet. 6' Paramount Enclosures require two Exhaust Transitions. **Requires installation.** Contact Labconco ordering information on remote blowers and ductwork. Shipping weight 18 lbs. (8 kg)



### Sash Closures

Bi-fold doors allow the sash opening to be closed to prevent contaminants from entering the enclosure during periods of non-use. Include powder-coated steel doors and mounting hardware. **Require installation.**

| Catalog # | Sash Closure Dimensions (w x h) | Ship. Wt. (lbs./kg) |
|-----------|---------------------------------|---------------------|
| 6963900   | 24.0" x 9.4" (61.0 x 23.9 cm)   | 10/5                |
| 6963901   | 36.0" x 9.4" (91.4 x 23.9 cm)   | 12/6                |
| 6963902   | 36.0" x 12.0" (91.4 x 30.5 cm)  | 15/7                |
| 6963903   | 48.0" x 9.4" (121.9 x 23.9 cm)  | 16/7                |
| 6963904   | 48.0" x 12.0" (121.9 x 30.5 cm) | 20/9                |
| 6963905   | 60.0" x 9.4" (152.4 x 23.9 cm)  | 25/12               |
| 6963906   | 72.0" x 12.0" (182.9 x 30.5 cm) | 30/14               |

Contact Labconco for additional base stands and cabinets. See ordering information on Utility Shelves, Bottle Holder and Tissue Holder on page 23.



## Fume Adsorbers



*Left: Fume Adsorber 3955200 is shown with Flat Solid Epoxy Work Surface 4882803 and Protector Solvent Storage Cabinet 9902000. Work surface and base cabinet must be ordered separately. Right and Below: Fume Adsorber-2 3955400 is shown with Flat Solid Epoxy Work Surface 4882804 and Protector Standard Storage Cabinets 9904500 and 9904200. Work surface and base cabinets must be ordered separately.*



Fume Adsorbers are designed for light duty applications involving organic solvents, formaldehyde, ammonia or low molecular weight amines. Fume Adsorbers use carbon filtration to trap vapors so that safe, filtered air is returned to the laboratory. No outside ducting is required. These portable, low profile enclosures fit easily on counter-tops with overhanging cabinets and are available in two widths.

Each Fume Adsorber includes one carbon filter (each Fume Adsorber-2 includes two) that adsorbs vapors from organic solvents, formaldehyde or ammonia, depending on the filter.

### All models feature:

- ▲ Built-in motorized impeller to provide face velocity up to 35 fpm (Fume Adsorber-2 models include two impellers.)
- ▲ Powder-coated steel housing with perforated baffle for uniform airflow.
- ▲ Clear, one-piece, 3/8" thick, shatter-resistant acrylic canopy.
- ▲ Quiet operation at 58-63 dBA.
- ▲ Pre-wired with rear-mounted auxiliary electrical receptacle and top-mounted blower switch with circuit breaker.
- ▲ Rear-mounted air sampling port.
- ▲ Exterior dimensions: 15.4" h x 23.4" d.
- ▲ Interior dimensions: 13.5" h x 14.5" d.
- ▲ Available in two widths: 30.0" and 60.0".
- ▲ ETL<sup>1</sup> listed (115 volt models).

### All models conform to the following regulations and standards:

- ▲ SEFA<sup>1</sup> 9-2010, DH I
- ▲ SEFA<sup>1</sup> 8-2010, Cabinet Surface Finish Tests
- ▲ UL<sup>1</sup> 61010-1 (115 volt models)
- ▲ CAN/CSA<sup>1</sup> C22.2 No. 61010-1 (115 volt models)
- ▲ CE<sup>1</sup> Conformity Marking (230 volt models)



<sup>1</sup>See page 26 for a list of regulations, standards and registered trademarks.

### Fume Adsorber Model 3955200 features one each and Fume Adsorber-2 Model 3955400 features two each:

- ▲ Replaceable 6 pound Type AC activated carbon filter, 26.0" w x 9.0" h, to adsorb organic vapors such as xylene and toluene. Adsorbs up to one third its weight.

### Fume Adsorber Model 3955201 features one each and Fume Adsorber-2 Model 3955401 features two each:

- ▲ Replaceable 7.5 pound impregnated carbon filter, 26.0" w x 9.0" h, treated to adsorb formaldehyde. Adsorption weight 10% (0.75 lb).

### Fume Adsorber Model 3955202 features one each and Fume Adsorber-2 Model 3955402 features two each:

- ▲ Replaceable 8.8 pound impregnated carbon filter, 26.0" w x 9.0" h, treated to adsorb ammonia and low molecular weight amine vapors. Adsorption weight 10% (0.88 lb).

### Fume Adsorber Models 3955200, 3955201 and 3955202 and Fume Adsorber-2 Models 3955400, 3955401 and 3955402 feature:

- ▲ Operation on 115 volts, 60 Hz, 2 amps.
- ▲ 6.5' IEC three-wire cord with plug.

### Fume Adsorber Models 3955220, 3955221 and 3955222 and Fume Adsorber-2 Models 3955420, 3955421 and 3955422 feature:

- ▲ Operation on 230 volts, 50 Hz, 1 amp.
- ▲ 9' IEC three-wire cord. **An electrical plug is required.**

### If not placed on existing casework, all models require:

- ▲ **Flat Work Surface.** Contact Labconco.
- ▲ **Base Stand or Cabinet.** Contact Labconco.



# Ordering Information

F U M E   A D S O R B E R S

| Catalog # | Description   | Shipping Wt. lbs./kg |
|-----------|---|----------------------|
| 3955200   | Fume Adsorber with Activated Carbon Filter for Organic Vapors.<br>30.0" exterior width, 29.25" interior width, for 115 volt, 60 Hz, 2 amp operation.  | 67/30                |
| 3955201   | Fume Adsorber with Impregnated Carbon Filter for Formaldehyde Vapors.<br>30.0" exterior width, 29.25" interior width, for 115 volt, 60 Hz, 2 amp operation.   | 67/30                |
| 3955202   | Fume Adsorber with Impregnated Carbon Filter for Ammonia Vapors.<br>30.0" exterior width, 29.25" interior width, for 115 volt, 60 Hz, 2 amp operation.  | 67/30                |
| 3955220*  | Fume Adsorber with Activated Carbon Filter for Organic Vapors.<br>30.0" exterior width, 29.25" interior width, for 230 volt, 50 Hz, 1 amp operation.  | 67/30                |
| 3955221*  | Fume Adsorber with Impregnated Carbon Filter for Formaldehyde Vapors.<br>30.0" exterior width, 29.25" interior width, for 230 volt, 50 Hz, 1 amp operation.   | 67/30                |
| 3955222*  | Fume Adsorber with Impregnated Carbon Filter for Ammonia Vapors.<br>30.0" exterior width, 29.25" interior width, for 230 volt, 50 Hz, 1 amp operation.  | 67/30                |
| 3955400   | Fume Adsorber-2 with Activated Carbon Filters for Organic Vapors.<br>60.0" exterior width, 59.25" interior width, for 115 volt, 60 Hz, 2 amp operation.   | 135/61               |
| 3955401   | Fume Adsorber-2 with Impregnated Carbon Filters for Formaldehyde Vapors.<br>60.0" exterior width, 59.25" interior width, for 115 volt, 60 Hz, 2 amp operation.  | 137/62               |
| 3955402   | Fume Adsorber-2 with Impregnated Carbon Filters for Ammonia Vapors.<br>60.0" exterior width, 59.25" interior width, for 115 volt, 60 Hz, 2 amp operation.   | 139/63               |
| 3955420*  | Fume Adsorber-2 with Activated Carbon Filters for Organic Vapors.<br>60.0" exterior width, 59.25" interior width, for 230 volt, 50 Hz, 2 amp operation.   | 135/61               |
| 3955421*  | Fume Adsorber-2 with Impregnated Carbon Filters for Formaldehyde Vapors.<br>60.0" exterior width, 59.25" interior width, for 230 volt, 50 Hz, 2 amp operation.  | 137/62               |
| 3955422*  | Fume Adsorber-2 with Impregnated Carbon Filters for Ammonia Vapors.<br>60.0" exterior width, 59.25" interior width, for 230 volt, 50 Hz, 2 amp operation.   | 139/63               |
| 6961300   | Replacement Activated Carbon Filter for use with organic vapors. 6 pounds of activated carbon.<br>Adsorbs up to one third of its weight. Adsorption capacity dependent on chemical properties.** One each.<br>Fume Adsorber Models 3955200 and 3955220 include one filter; Fume Adsorber-2 Models 3955400 and 3955420 include two filters.      | 9/4                  |
| 6961301   | Replacement Formaldehyde Carbon Filter for use with formaldehyde and glutaraldehyde. 7.5 pounds of impregnated carbon. Adsorption weight 10% (0.75 lb.). Adsorption volume 850 ml of 37% formalin. One each.<br>Fume Adsorber Models 3955201 and 3955221 include one filter; Fume Adsorber-2 Models 3955401 and 3955421 include two filters.    | 11/5                 |
| 6961302   | Replacement Ammonia Carbon Filter for use with ammonia and low molecular weight amines. 8.8 pounds of impregnated carbon. Adsorption weight 10% (0.88 lbs.). Adsorption volume 800 ml of 50% ammonia. One each.<br>Fume Adsorber Models 3955202 and 3955222 include one filter; Fume Adsorber-2 Models 3955402 and 3955422 include two filters. | 13/6                 |
| 6924900   | Syringe Kit for carbon saturation detection. Contaminant detector tubes are not included (See Detector Tubes below or contact your safety supply distributor).  | 1/0.5                |
| 6926000   | Formaldehyde Detector Tubes, package of 3.  | 0.5/0.2              |
| 6925700   | Ammonia Detector Tubes, package of 3.   | 0.5/0.2              |

\*International electrical configuration

\*\*Complete the Chemical Assessment Form at [www.labconco.com](http://www.labconco.com) or call 800-821-5525 or 816-333-8811.



# Protector® XVS Ventilation Stations

## FEATURES & BENEFITS

Protector XVS Ventilation Stations provide an economical alternative to traditional fume hoods. With their low profile and clear sides, top and sash, Protector XVS Ventilation Stations are well suited for classroom and educational laboratory environments where supervision or demonstrations are required. They may also be used as weighing stations, light duty fume hoods, solvent cleaning work bays, and veterinary pathology and cytology enclosures. With smaller working heights and available in widths from 2', XVS Stations exhaust less tempered room air and

conserve more energy than traditional hoods. They have no switches, wiring or service fixtures that add incremental costs.

Protector XVS Stations may be connected to a remote blower and exhausted to the outside. Alternatively, they may be connected to the FilterMate Portable Exhauster(s), which uses a carbon filter(s), a HEPA filter(s) or HEPA/carbon filter combination to remove fumes and vapors and/or hazardous particulates from the exhaust air without ducting.

■ **Tempered safety glass front sash, sides and top** offer excellent visibility, ambient light and protection. Glass provides better fire, scratch and chemical resistance than acrylic and dissipates static charge.

■ **Sturdy powder-coated aluminum frame and steel rear plenum and baffle** dissipate static charge and provide durability and better chemical resistance compared to acrylic models. No plastic-to-plastic bonding is used.

■ **Upper dilution air supply** introduces room air at the top of the sash to dilute contaminants in the upper chamber and bathes the back of the sash with clean air.

■ **Patented\* rear baffle with zones of perforations** promotes horizontal laminar airflow to maximize containment. The baffle pivots down and is easily removable for cleaning.

■ **Ergonomic angled sash** allows a closer view, reduces glare and provides a more comfortable operating position than vertical sashes.

■ **Patented\* upper containment sash foil** bleeds air into the enclosure to direct concentrations of contaminants away from the operator's breathing zone.

■ **8", 10" or 12" high sash opening** limits exhaust demand, conserves costly tempered room air and requires a smaller remote blower than most fume hoods.

■ **Deep interior** easily accommodates a variety of apparatus including large balances. Models are available with a 23.4" interior depth. Some 5', 6' and 8' models have 30.0" interior depths.

■ **Flexible exhaust options.** Rectangular exhaust openings on the top and bottom allow the Protector XVS Ventilation Station to be connected to ductwork for exhausting to the outside or to FilterMate™ Portable Exhauster(s) for filtered removal of fumes, particulates or powders. Using the bottom exhaust opening keeps ductwork hidden, maximizing room visibility.

■ **Side-entry air foils** allow air to sweep across the interior glass surfaces to enhance containment.

■ **Patented\* Clean-Sweep™ air foil** allows air to sweep the work surface for maximum containment. Airflow openings pull inflow air from under the air foil so that clean air continually flows through the air foil creating a constant barrier of protection from contaminants.

■ **Two utility ports** allow passage of tubing, electrical cords and interface cables from inside to back exterior for connection to services.

■ **Modified ASHRAE 110-1995 conformity independently verified by ECT, Inc.**

■ **Particulate containment independently verified by SafeBridge Consultants, Inc.\*\***

■ **Low profile design** requires less space than most ventilated enclosures.



■ **Left-side mounted waste chute**, standard on some 5', 6' and 8' models, isolates contaminated waste in a sealable bag (bags not included).

■ Exclusive Feature \* U.S. Patent No. 6,461,233 \*\*Contact Labconco for more information.



# Protector® XVS™ Ventilation Stations



*Far left: 6' Protector XVS Ventilation Station 4868060 is shown with Solid Epoxy Dished Work Surface 3908411 and Protector Standard Storage Cabinets 9904300 and 9904000. Blower or FilterMate Portable Exhauster, ductwork, work surface and supporting base must be ordered separately.*

*Left: 2' Protector XVS Ventilation Station 4862030 is shown with Solid Epoxy Dished Work Surface 3908400 and Telescoping Base Stand 3747000. Blower or FilterMate Portable Exhauster, ductwork, work surface and supporting base must be ordered separately.*



Requires Ductwork and Blower or FilterMate Portable Exhauster

## All models feature:

- ▲ By-pass airflow design.
- Deep interior of 23.4" or 30.0" depending on the model.
- Clean-Sweep\* air foil.
- Upper dilution air supply.
- Upper containment sash foil.
- Zone-perforated, pivoting rear baffle.\*
- ▲ Side-entry air foils.
- ▲ Powder-coated aluminum frame and steel rear plenum and baffle. No plastic-to-plastic bonding is used.
- ▲ Clear 1/4" thick tempered safety glass front sash, sides and top.
- Ergonomic 20° angled and hinged, pivoting sash with wiping seal. Sashes on 5', 6' and 8' models incorporate an external gas-assist lift.
- ▲ Models with 8.0" sash opening height have 16.5" locking height and 19.0" maximum loading height. Models with 10.0" or 12.0" sash opening height have 25.75" locking height and 28.25" maximum loading height.
- ▲ Two utility ports with iris openings and plastic plugs.
- ▲ 2" x 10" rectangular exhaust openings at the top and bottom. 5', 6' and 8' models include three openings on the top and bottom. Cover(s) provided for unused openings.
- Particulate containment independently verified by SafeBridge Consultants, Inc.\*\*
- ▲ Modified ASHRAE 110-1995 conformity as low as 50 fpm independently verified by ECT, Inc.†††

## All models conform to the following regulations and standards:

- ▲ SEFA\*\* 9-2010, DH I (when connected to a FilterMate Portable Exhauster)
- ▲ SEFA\*\* 1-2010 (Ducted models only)
- ▲ SEFA\*\* 8-2010, Cabinet Surface Finish Tests
- ▲ Modified ASHRAE\*\* 110-1995
- ▲ ANSI\*\* Z9.5-2011

## 5', 6' and 8' models with 35.5" exterior depth include:

- ▲ Left-side mounted waste chute. Bags not included. Minimum bag size required: 10" x 16".

## All models require:

- ▲ Remote blower or FilterMate Portable Exhauster(s) (each sold separately). Contact Labconco for blower information. See pages 20-21 for FilterMate Ordering Information.
- ▲ Work surface. See page 22.
- ▲ Exhaust Transition Adapters. See page 25.
- ▲ Supporting base. Contact labconco.
- ▲ Ductwork. See page 25.

## Optional accessories:

- ▲ Guardian™ Airflow Monitors. See page 24.
- ▲ Fluorescent Task Lights. See page 23.
- ▲ Utility Shelves, Bottle Holder and Tissue Holder. See page 23.
- ▲ Waste Chute Stopper. See page 24.
- ▲ Waste Chute Bags. Contact your laboratory supply dealer.

| Nominal Width | Height | Sash Opening Ht. | Total Exhaust CFM and Static Pressure (w.g.) |       |        |         |        |       |
|---------------|--------|------------------|--|-------|--------|---------|--------|-------|
|               |        |                  | 100 fpm                                      | S.P.  | 80 fpm | S.P.    | 60 fpm | S.P.  |
| 2 Feet        | Std.   | 8"               | 120  | 0.05" | 95     | 0.03"   | 70     | 0.02" |
| 2 Feet        | Tall   | 10"              | 150  | 0.08" | 120    | 0.05"   | 90     | 0.03" |
| 3 Feet        | Std.   | 8"               | 185  | 0.10" | 145    | 0.06"   | 110    | 0.04" |
| 3 Feet        | Tall   | 10"              | 230  | 0.15" | 185    | 0.10"   | 140    | 0.06" |
| 4 Feet        | Std.   | 8"               | 250  | 0.16" | 200    | 0.10"   | 150    | 0.06" |
| 4 Feet        | Tall   | 10"              | 310  | 0.24" | 250    | 0.16"   | 185    | 0.09" |
| 5 Feet        | Std.   | 8"               | 315  | 0.23" | 250    | 0.15**  | 190    | 0.08" |
| 5 Feet        | Tall   | 12"              | 480  | 0.54" | 385    | 0.35**  | 290    | 0.20" |
| 6 Feet        | Std.   | 8"               | 380  | 0.32" | 305    | 0.21**  | 230    | 0.12" |
| 6 Feet        | Tall   | 12"              | 580  | 0.75" | 465    | 0.48**  | 350    | 0.27" |
| 8 Feet        | Std.   | 8"               | 510  | 0.18" | 410    | 0.12*** | 310    | 0.07" |
| 8 Feet        | Tall   | 12"              | 775  | 0.42" | 620    | 0.27*** | 465    | 0.15" |

\*\*See page 26 for a list of regulations, standards and registered trademarks.

†Static pressure when one center exhaust opening is used.

††Static pressure when two outer exhaust openings are used. Requires "T" Connector 3981600, not included. Contact Labconco. †††Exposure Control Technologies, Inc., Cary, NC. Contact Labconco for more information.

■ Exclusive Feature \* U.S. Patent No. 6,461,233



# Ordering Information & Dimensional Data

PROTECTOR® XVS™ VENTILATION STATIONS

## Protector® XVS Ventilation Stations

| Nominal Width | Catalog Number | Overall Height (E)<br>in./cm | Overall Depth (H)<br>in./cm | (A)<br>in./cm | (B)<br>in./cm | (C)<br>in./cm | (D)<br>in./cm | (F)<br>in./cm | (G)<br>in./cm | (I)<br>in./cm | (J)<br>in./cm | (K)<br>in./cm | Ship. Wt.<br>lbs./kg |
|---------------|----------------|------------------------------|-----------------------------|---------------|---------------|---------------|---------------|---------------|---------------|---------------|---------------|---------------|----------------------|
| 2 Feet        | <b>4862010</b> | 22.8/57.9                    | 29.0/73.7                   | 24.0/61.0     | 12.0/30.5     | 21.6/54.9     | 28.6/72.6     | 22.3/56.6     | 19.0/48.3     | 23.4/59.4     | 8.0/20.3      | —             | 105/48               |
| 2 Feet        | <b>4862030</b> | 32.0/81.3                    | 29.0/73.7                   | 24.0/61.0     | 12.0/30.5     | 21.6/54.9     | 37.8/96.0     | 31.5/80.0     | 27.7/70.4     | 23.4/59.4     | 10.0/25.4     | —             | 135/61               |
| 3 Feet        | <b>4863010</b> | 22.8/57.9                    | 29.0/73.7                   | 36.0/91.4     | 18.0/45.7     | 33.6/85.3     | 28.6/72.6     | 22.3/56.6     | 19.0/48.3     | 23.4/59.4     | 8.0/20.3      | —             | 135/61               |
| 3 Feet        | <b>4863030</b> | 32.0/81.3                    | 29.0/73.7                   | 36.0/91.4     | 18.0/45.7     | 33.6/85.3     | 37.8/96.0     | 31.5/80.0     | 27.7/70.4     | 23.4/59.4     | 10.0/25.4     | —             | 160/73               |
| 4 Feet        | <b>4864010</b> | 22.8/57.9                    | 29.0/73.7                   | 48.0/121.9    | 24.0/61.0     | 45.6/115.8    | 28.6/72.6     | 22.3/56.6     | 19.0/48.3     | 23.4/59.4     | 8.0/20.3      | —             | 160/73               |
| 4 Feet        | <b>4864030</b> | 32.0/81.3                    | 29.0/73.7                   | 48.0/121.9    | 24.0/61.0     | 45.6/115.8    | 37.8/96.0     | 31.5/80.0     | 27.7/70.4     | 23.4/59.4     | 10.0/25.4     | —             | 185/84               |
| 5 Feet        | <b>4865010</b> | 22.8/57.9                    | 29.0/73.7                   | 60.0/152.4    | 30.0/76.2     | 57.6/146.3    | 28.6/72.6     | 22.3/56.6     | 19.0/48.3     | 23.4/59.4     | 8.0/20.3      | 10.0/25.4     | 290/132              |
| 5 Feet        | <b>4865030</b> | 32.0/81.3                    | 29.0/73.7                   | 60.0/152.4    | 30.0/76.2     | 57.6/146.3    | 37.8/96.0     | 31.5/80.0     | 27.7/70.4     | 23.4/59.4     | 12.0/30.5     | 10.0/25.4     | 340/154              |
| 5 Feet*       | <b>4865060</b> | 32.0/81.3                    | 35.5/90.2                   | 60.0/152.4    | 30.0/76.2     | 57.6/146.3    | 37.8/96.0     | 31.5/80.0     | 27.7/70.4     | 30.0/76.2     | 12.0/30.5     | 10.0/25.4     | 380/172              |
| 6 Feet        | <b>4866010</b> | 22.8/57.9                    | 29.0/73.7                   | 72.0/182.9    | 36.0/91.4     | 69.6/176.8    | 28.6/72.6     | 22.3/56.6     | 19.0/48.3     | 23.4/59.4     | 8.0/20.3      | 10.0/25.4     | 340/154              |
| 6 Feet        | <b>4866030</b> | 32.0/81.3                    | 29.0/73.7                   | 72.0/182.9    | 36.0/91.4     | 69.6/176.8    | 37.8/96.0     | 31.5/80.0     | 27.7/70.4     | 23.4/59.4     | 12.0/30.5     | 10.0/25.4     | 395/179              |
| 6 Feet*       | <b>4866060</b> | 32.0/81.3                    | 35.5/90.2                   | 72.0/182.9    | 36.0/91.4     | 69.6/176.8    | 37.8/96.0     | 31.5/80.0     | 27.7/70.4     | 30.0/76.2     | 12.0/30.5     | 10.0/25.4     | 440/220              |
| 8 Feet        | <b>4868010</b> | 22.8/57.9                    | 29.0/73.7                   | 96.0/243.8    | 48.0/121.9    | 93.6/237.7    | 28.6/72.6     | 22.3/56.6     | 19.0/48.3     | 23.4/59.4     | 8.0/20.3      | 24.0/61.0     | 455/206              |
| 8 Feet        | <b>4868030</b> | 32.0/81.3                    | 29.0/73.7                   | 96.0/243.8    | 48.0/121.9    | 93.6/237.7    | 37.8/96.0     | 31.5/80.0     | 27.7/70.4     | 23.4/59.4     | 12.0/30.5     | 24.0/61.0     | 520/236              |
| 8 Feet*       | <b>4868060</b> | 32.0/81.3                    | 35.5/90.2                   | 96.0/243.8    | 48.0/121.9    | 93.6/237.7    | 37.8/96.0     | 31.5/80.0     | 27.7/70.4     | 30.0/76.2     | 12.0/30.5     | 24.0/61.0     | 580/263              |

\*Includes waste chute

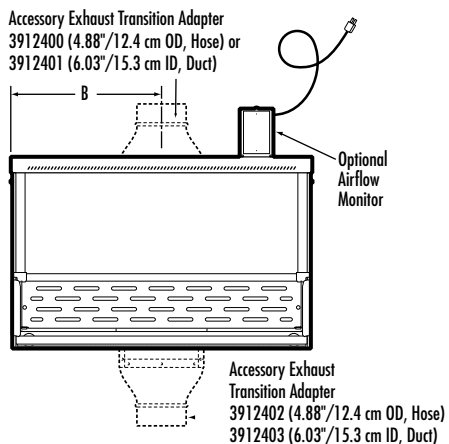

**FRONT**  
(2', 3', 4' Models)

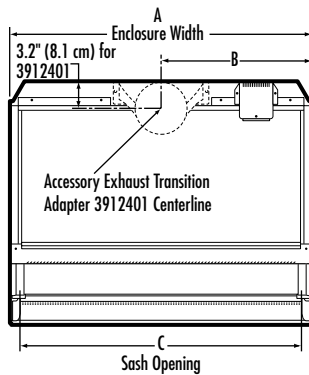

**TOP**  
(2', 3', 4' Models)

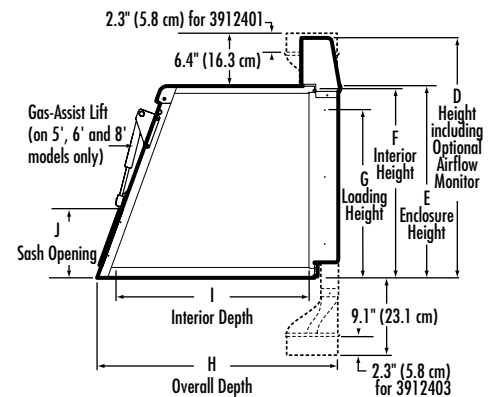

**SIDE (ALL MODELS)**

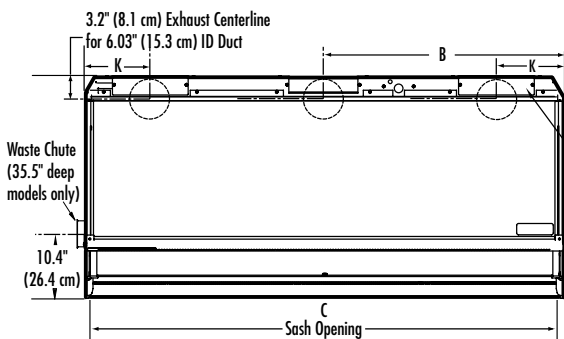

**TOP**  
(5', 6', 8' Models)

5' and 6' enclosures include five covers, two on top and three on the bottom. 8' enclosures include four covers, one on top and three on the bottom.

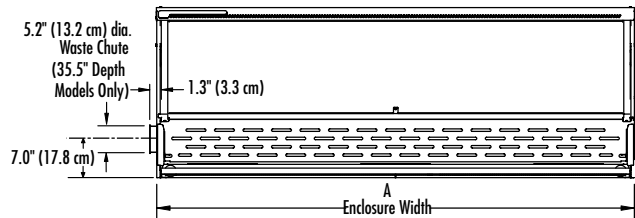

**FRONT**  
(5', 6', 8' Models)

Contact Labconco at 800-821-5525 or 816-333-8811 or visit [www.labconco.com](http://www.labconco.com) for detailed AutoCAD\* drawings.

\*See page 26 for a list of regulations, standards and registered trademarks.

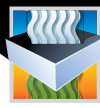

# Protector® Work Stations

## FEATURES & BENEFITS

Protector Work Stations are specifically designed for the needs of pathologists and histotechnologists. These enclosures rely on patented\* containment-enhancing features and face velocities from 60 to 100 fpm to rid the laboratory of solvent vapors associated with gross sectioning, trimming, coverslipping and staining.

Protector Work Stations are available in two configurations. Models designed for connection to a remote blower or house exhaust system offer protection from a broad range of chemicals and are recommended when chemical concentrations are high, unknown or unpredictable. In lieu of outside ducting, these models may also be

connected to the FilterMate Portable Exhauster, which returns filtered air to the laboratory. The FilterMate Portable Exhauster and Filters are sold separately.\*\*

Alternatively, if ducting to the outside is not feasible, Protector Work Stations with built-in blower are available. These enclosures accommodate two large carbon filters—Organic, Formaldehyde and Ammonia—used in any combination. The filters keep low concentrations of these chemicals below OSHA-recommended time-weighted average (TWA) levels, restoring clean air to the laboratory. Carbon Filters are sold separately.

**Patented\* Type 304 stainless steel rear baffle with zones of perforations** promotes horizontal laminar airflow to maximize containment. The baffle pivots down and is easily removable for cleaning. On Models 3930000 and 3930020, the area behind the baffle accommodates two Carbon Filters (sold separately).

**Ergonomic 20° angled sash** allows a closer view, reduces glare and provides a more comfortable operating position than vertical sashes. The hinged sash with spring-loaded latch pivots upward and locks to a height of 19.0" for loading and cleaning. The sash's wiping seals help keep contaminants contained.

**Performance tested to modified ASHRAE 110-1995.**

**Upper dilution air supply** introduces room air at the top of the sash to dilute contaminants in the upper chamber and bathes the back of the sash with clean air.

**Optional Guardian™ 1000 Digital or Guardian™ 500 Airflow Monitor** alerts the user to face velocities outside of pre-set range. The Guardian™ 1000 Digital Monitor also has a RS232 port for connection to a user-supplied computer.

**Front-mounted light and blower switches.**

**Glare-free fluorescent lighting.**

**Two convenient utility ports with iris openings (Models 3930001 and 3930021 only)** allow passage of tubing and electrical cords from equipment inside the enclosure through the back for connection to services. Plugs are provided to seal the ports when not in use.

**Side-entry air foils** allow air to sweep across the interior side glass surfaces to enhance containment.

**Patented\* Clean-Sweep™ air foil** allows air to sweep the work surface for maximum containment. Airflow openings pull inflow air from under the air foil so that clean air continually flows through the air foil creating a constant barrier of protection from contaminants. The air foil's ergonomic design provides a comfortable position for the operator's forearms.

**Flexible exhaust options (Models 3930001 and 3930021 only).** 2" x 10" rectangular exhaust openings on the top and bottom allow the Protector Work Station to be connected to ductwork for exhausting to the outside or to a FilterMate Portable Exhauster\*\* for filtered removal of vapors, particles or a combination of both. Using the bottom exhaust opening keeps ductwork hidden, maximizing room visibility.

**Rear-mounted electrical receptacle,** activated by the blower switch, may be used to provide power to the optional Guardian Airflow Monitor.

**ETL-listed.** All 115 volt models carry the ETL mark signifying that they are certified to UL 3101-1/61010-1 and CAN/CSA C22.2 No. 1010.1.

**Sturdy and chemical-resistant construction.** The frame and rear plenum are powder-coated aluminum and steel. The sides and front sash are fire-, scratch- and chemical-resistant 1/4" thick tempered safety glass.

**Built-in motorized impeller (Models 3930000 and 3930020 only)** is dynamically-balanced for quiet operation.

**Speed control (Models 3930000 and 3930020 only)** allows a certified technician to validate and adjust the speed of the motorized impeller to achieve the desired inflow velocity.

**CE mark.** All 230 volt, 50 Hz models conform to the CE (European Community) requirements for electrical safety and electromagnetic compatibility.

**8" high sash opening** limits exhaust demand, conserves costly tempered room air and requires a smaller remote blower than most fume hoods.

**Patented\* upper containment sash foil** bleeds air into the enclosure to direct concentrations of contaminants away from the operator's breathing zone.



**Optional Work Surface 6942003\*\*** of solid black epoxy is corrosion and stain resistant and dished to contain spills. Includes a 10" x 14" x 6" deep molded epoxy sink; corrosion-resistant, chrome-plated gooseneck fixture with vacuum breaker and two faucet controls. A retractable hose with spray nozzle speeds clean up. A Solid Epoxy Work Surface without sink is also available. Contact Labconco for ordering information.

**Exclusive Feature** \*U.S. Patent No. 6,461,233

\*\*See pages 20-21 for ordering information on FilterMate Portable Exhausters  
See page 23 for ordering information on Work Surface 6942003.





# Protector® Work Stations



Protector Work Station 3930001 is shown on Work Surface with Sink 6942003 and Telescoping Base Stand 3746702. Blower, ductwork, work surface and supporting base must be ordered separately.

## All models feature:

- Clean-Sweep\* air foil.
- Upper dilution air supply.
- Upper containment sash foil.\*
- Zone-perforated Type 304 stainless steel rear baffle that pivots down and is removable for cleaning.\*
- ▲ Side-entry air foils.
- ▲ Powder-coated aluminum frame and steel rear plenum.
- ▲ 1/4" thick tempered safety glass front sash and sides.
- ▲ 8" high sash opening.
- ▲ Ergonomic 20° angled and hinged sash with wiping seals and spring-loaded latch that pivots upward and locks to a 19.0" height.
- ▲ Fluorescent lighting.
- ▲ Light and blower switches.
- ▲ Exterior rear-mounted electrical receptacle.
- ▲ ETL<sup>†</sup> listed (115 volt models).

## All models conform to the following regulations and standards:

- ▲ SEFA<sup>†</sup> 9-2010, DH I (Built-in blower models or models connected to FilterMate Portable Exhauster only)
- ▲ SEFA<sup>†</sup> 1-2010 (Ducted models only)
- ▲ SEFA<sup>†</sup> 8-2010, Cabinet Surface Finish Tests
- ▲ Modified ASHRAE<sup>†</sup> 110-1995
- ▲ ANSI<sup>†</sup> Z9.5-2011
- ▲ UL<sup>†</sup> 61010-1 (115 volt models)
- ▲ CAN/CSA<sup>†</sup> C22.2 No. 61010-1 (115 volt models)
- ▲ CE<sup>†</sup> Conformity marking (230 volts models)

## Models 3930000 and 3930020 are designed for use with two carbon filters (not included) and feature:

- ▲ Built-in dynamically-balanced motorized impeller.
- ▲ Speed control.
- ▲ Baffle with two release knobs that pivots down for filter access.
- ▲ Quiet operation. See chart below.

## Models 3930000 and 3930020 require (not included):

- ▲ Two Carbon Filters. See page 17.

## Models 3930001 and 3930021 are designed for use with remote blower or FilterMate Portable Exhauster and feature:

- ▲ 2" x 10" rectangular exhaust openings on the top and bottom.
- ▲ Two utility ports with iris openings and plugs.
- ▲ Static pressure loss from 0.06" to 0.16". See chart below.

## Models 3930001 and 3930021 require (not included):

- ▲ Remote blower, house exhaust or FilterMate™ Portable Exhauster. Contact Labconco for Remote Blower. See pages 20-21 for FilterMate.
- ▲ Exhaust Transition Adapters. See page 25.
- ▲ Ductwork. Contact Labconco.

## All models require (not included):

- ▲ Supporting work surface. See page 23.
- ▲ Supporting base. Contact Labconco.

## Optional accessories include:

- ▲ Guardian™ Airflow Monitors. See page 24.
- ▲ Utility Shelves, Bottle Holder and Tissue Holder. See page 23.
- ▲ Remote Blowers. See page 25 or contact Labconco.

| Face Velocity (fpm) | Exhaust Volume (CFM) | Noise Pressure db(A) (Models 3930000 & 3930020) | Static Pressure Loss (Inches of H <sub>2</sub> O) (Models 3930001 & 3930021) |
|---------------------|----------------------|---|--|
| 60                  | 150                  | 57-59   | 0.06"  |
| 80                  | 200                  | 62-64   | 0.10"  |
| 100                 | 250                  | 69-71   | 0.16"  |

\*U.S. Patent No. 6,461,233

<sup>†</sup>See page 26 for a list of regulations, standards and registered trademarks.

■ Exclusive Feature



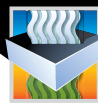

# Ordering Information & Dimensional Data

PROTECTOR® WORK STATIONS

| Catalog Number | Electrical Requirements     | Power Cord & Plug | Blower  | Carbon Filters | Shipping Weight lbs./kg |
|----------------|-----------------------------|-------------------|---|----------------|-------------------------|
| 3930000        | 115 volts, 60 Hz, 10 amps   | 6.5'              | Built-in  | Requires two   | 120/54                  |
| 3930001        | 115 volts, 60 Hz, 10 amps   | 6.5'              | Requires remote blower, house exhaust or FilterMate Portable Exhauster* |                | 100/45                  |
| 3930020        | 230 volts, 50/60 Hz, 5 amps | 9'. No Plug.      | Built-in  | Requires two   | 120/54                  |
| 3930021        | 230 volts, 50/60 Hz, 5 amps | 9'. No Plug.      | Requires remote blower, house exhaust or FilterMate Portable Exhauster* |                | 100/45                  |

\*\*See page 25 for ordering information on Remote Blowers and pages 20-21 for ordering information on FilterMate Portable Exhausters.



## Carbon Filters and Accessories for use with Protector Work Stations

Protector Work Stations 3930000 or 3930020 require two each Carbon Filters, either two of the same filter or a combination of two filters.

| Catalog # | Description  | Shipping Wt. lbs./kg |
|-----------|--|----------------------|
| 3924200   | Organic Carbon Filter, Type RL10. Contains 11 pounds of granular activated carbon media. | 12/5.4               |
| 3924201   | Formaldehyde Carbon Filter. Contains a minimum of 13 pounds of impregnated carbon media. | 14/6.4               |
| 3924202   | Ammonia Carbon Filter. Contains a minimum of 15 pounds of impregnated carbon media.      | 16/7.3               |
| 6925700   | Ammonia Detector Tubes, package of 3.  | 0.5/0.2              |
| 6926000   | Formaldehyde Detector Tubes, package of 3.   | 0.5/0.2              |
| 6924900   | Syringe Kit for carbon filter saturation detection.                                      | 1/0.5                |

Labconco strongly recommends ordering and keeping an extra set of filters to have readily available when filters become saturated and require replacement.

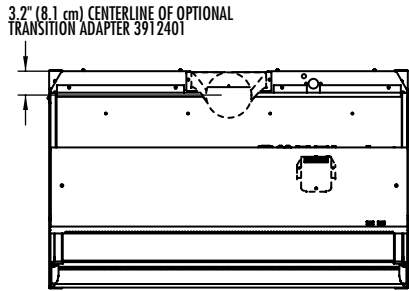

**TOP**  
(Models 3930001 & 3930021)

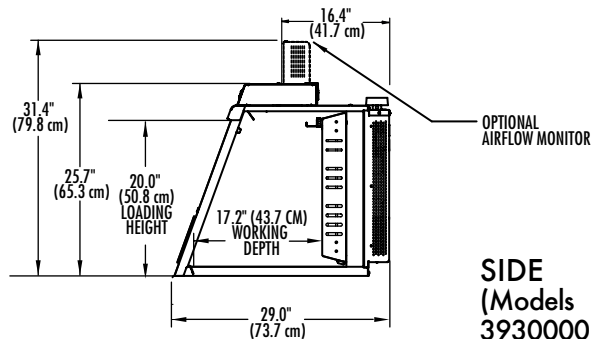

**SIDE**  
(Models 3930000 & 3930020)

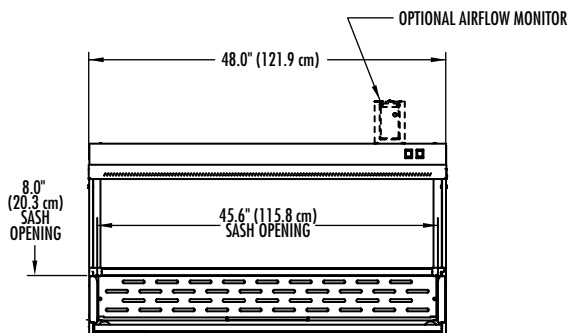

**FRONT**  
(All Models)

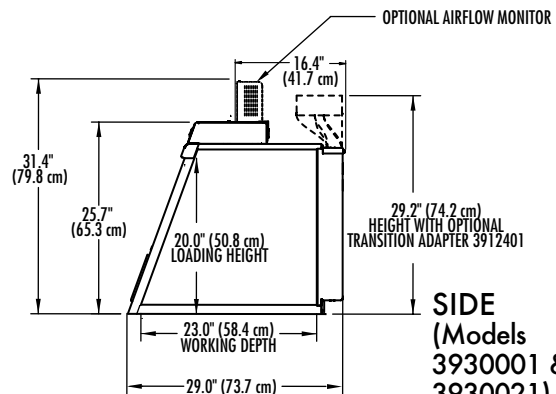

**SIDE**  
(Models 3930001 & 3930021)



## Protector® Demonstration Hoods



Protector Demonstration Hood System 3945001.

Protector Demonstration Hoods are low profile, light-duty fume hoods designed to provide 360° of close observation of procedures during educational demonstrations.

### All models feature:

- Deep 23" interior that easily accommodates a variety of apparatus.
- Patented\* Clean-Sweep™ air foil that allows air to sweep the work surface for maximum containment. Airflow openings pull inflow air from under the air foil so that clean air continually flows through the air foil creating a constant barrier of protection from contaminants.
- ▲ Upper containment sash foil that bleeds air into the enclosure to direct concentrations of contaminants away from the operator's breathing zone.
- Upper dilution air supply that introduces room air at the top of the sash to dilute concentrations in the upper chamber and bathes the back of the sash with clean air.
- Clear rear baffle that directs air streams to the back of the interior for removal through the exhaust connection. The baffle may be pivoted downward for cleaning.
- ▲ Side-entry air foils that allow air to sweep across the interior glass surfaces to enhance containment.
- ▲ Powder-coated aluminum frame.
- ▲ Tempered safety glass front sash, sides, rear baffle and top that offer excellent 360° visibility, ambient light and protection. Glass provides better fire, scratch and corrosion resistance than acrylic.
- ▲ 8" high sash opening that limits exhaust demand, conserves costly tempered room air and requires a smaller remote blower than most fume hoods. Tall models, 32.0" high, have a 10" high sash opening.

- Ergonomic angled sash allows a closer view, reduces glare and provides a more comfortable operating position than vertical sashes. Models, 22.8" high, have a 20° angle; models, 32.0" high, have a 14° angle. The hinged sash pivots upward and locks to a loading height of 19.0" or 27.7" depending on the model.
- ▲ Lower exhaust tissue screen.
- ▲ Two utility ports with iris openings that allow passage of tubing, electrical cords and interface cables from inside to back exterior for connection to services.
- ▲ Flexible exhaust options. 2" x 10" rectangular exhaust collars on the top and bottom allow the Protector Demonstration Hood to be connected to ductwork for exhausting to the outside or to a FilterMate Portable Exhauster for filtered removal of fumes and/or particulates. Using the bottom exhaust collar keeps ductwork hidden, maximizing room visibility.

### All models conform to the following regulations and standards:

- ▲ SEFA<sup>1</sup> 9-2010, DH I (when connected to a FilterMate Portable Exhauster)
- ▲ SEFA<sup>1</sup> 1-2010 (Ducted models only)
- ▲ SEFA<sup>1</sup> 8-2010, Cabinet Surface Finish Tests
- ▲ Modified ASHRAE<sup>1</sup> 110-1995
- ▲ ANSI<sup>1</sup> Z9.5-2011
- ▲ UL<sup>1</sup> 61010-1 (115 volt models)
- ▲ CAN/CSA<sup>1</sup> C22.2 No. 61010-1 (115 volt models)
- ▲ CE<sup>1</sup> Conformity Marking (230 volt models)

### System Models 3945000, 3945001, 3945020 & 3545021 also feature:

- ▲ Cart of glacier white powder-coated tubular steel with black 1" thick solid epoxy dished work surface, handle bar, bottom shelf and 4" diameter toe-locking casters.
- ▲ FilterMate Portable Exhauster designed for use with two Carbon Filters or one Carbon Filter and one HEPA Filter (Filters are not included. See page 22 for ordering information.) Includes 8 feet of 5" ID flexible gray polypropylene hose, two clamps, a 4.88" OD Lower Transition Adapter for connection to the bottom of the Protector Demonstration Hood, and an IEC 3-wire electrical cord with plug.
- ▲ ETL<sup>1</sup> listed (115 volt models).

### Models 3944300 & 3944301 require:

- ▲ **Connection to a remote blower, house exhaust or FilterMate Portable Exhauster.** See pages 20-21 for FilterMate. See page 25 for Remote Blowers and Ductwork.
- ▲ **Work surface and supporting base.** See page 23 for Cart. See page 22 for work surface. Contact Labconco for base stands and cabinets.
- ▲ Exhaust Transition Adapters. See page 25.

### Accessories include:

- ▲ Fluorescent Task Lights. See page 23.
- ▲ Exhaust Dampers. See page 25.
- ▲ Guardian™ Airflow Monitors. See page 24.
- ▲ Remote Blowers. See page 25 or contact Labconco.

| Nominal Width | Overall Height | Sash Opening Height | Total Exhaust CFM and Static Pressure |       |        |       |        |       |
|---------------|----------------|---------------------|---------------------------------------|-------|--------|-------|--------|-------|
|               |                |                     | 100 fpm                               | S.P.  | 80 fpm | S.P.  | 60 fpm | S.P.  |
| 3 Feet        | 22.8"          | 8"                  | 185                                   | 0.10" | 145    | 0.06" | 110    | 0.04" |
| 3 Feet        | 32.0"          | 10"                 | 230**                                 | 0.15" | 185    | 0.10" | 140    | 0.06" |

<sup>1</sup>See page 26 for a list of regulations, standards and registered trademarks.

\*\* FilterMate Portable Exhauster with two filters provides up to 220 CFM and with single filter provides up to 270 CFM.

■ Exclusive Feature \* U.S. Patent No. 6,461,233



# Ordering Information & Dimensional Data

PROTECTOR® DEMONSTRATION HOODS

| Nominal Width  | Catalog Number   | Electrical Requirements     | Enclosure Height | Shipping Weight lbs./kg |
|--|------------------|-----------------------------|------------------|-------------------------|
| <b>Protector Demonstration Hoods</b>   |                  |                             |                  |                         |
| 3 Feet   | <b>3944300</b>   | not applicable              | 22.8" (57.9 cm)  | 75/34                   |
| 3 Feet   | <b>3944301</b>   | not applicable              | 32.0" (81.3 cm)  | 85/39                   |
| <b>Protector Demonstration Hood Systems—include Cart with Work Surface, Lower Transition Adapter and FilterMate Portable Exhauster for use with two Carbon Filters or one Carbon Filter and one HEPA Filter in any combination.*</b> |                  |                             |                  |                         |
| 3 Feet   | <b>3945000</b>   | 115 volts, 60 Hz, 10 amps   | 22.8" (57.9 cm)  | 125/57                  |
| 3 Feet   | <b>3945001</b>   | 115 volts, 60 Hz, 10 amps   | 32.0" (81.3 cm)  | 135/61                  |
| 3 Feet   | <b>3945020**</b> | 230 volts, 50/60 Hz, 5 amps | 22.8" (57.9 cm)  | 125/57                  |
| 3 Feet   | <b>3945021**</b> | 230 volts, 50/60 Hz, 5 amps | 32.0" (81.3 cm)  | 135/61                  |

\* Filters are required but not included. See page 22 for ordering information.

\*\* International electrical configuration

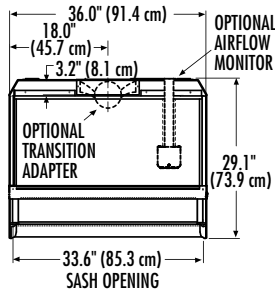

**TOP**  
(3944300, 3944301)

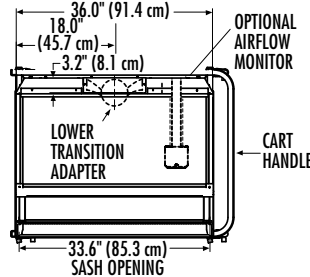

**TOP**  
(3945000, 3945001,  
3945020 & 3945021)

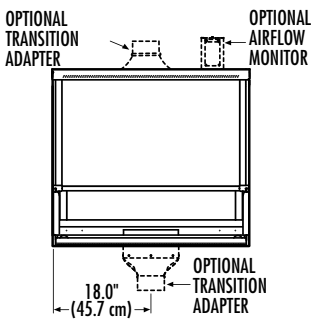

**FRONT**  
(3944300, 3944301)

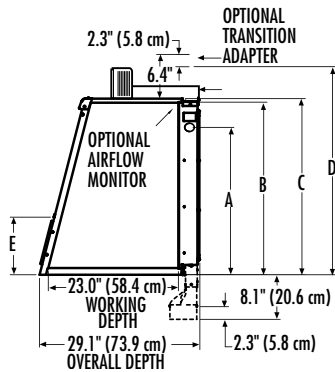

**SIDE**  
(3944300, 3944301)

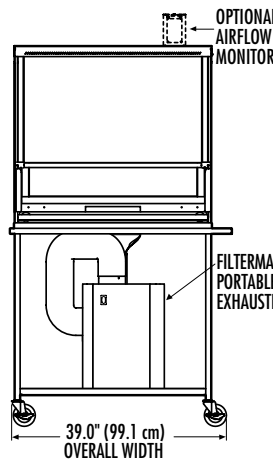

**FRONT**  
(3945000, 3945001,  
3945020 & 3945021)

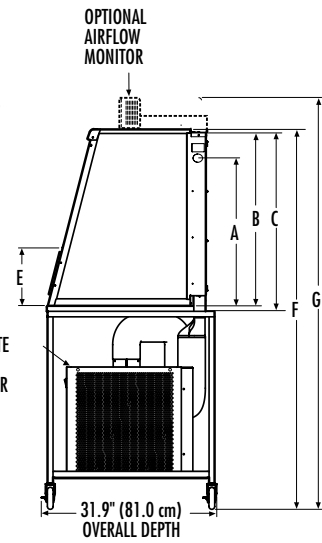

**SIDE**  
(3945000, 3945001,  
3945020 & 3945021)

|                                       | A                              | B                               | C                                | D                                 | E                            | F                              | G  |
|---------------------------------------|--------------------------------|---------------------------------|----------------------------------|-----------------------------------|------------------------------|--------------------------------|--|
| <b>3944300, 3945000 &amp; 3945020</b> | 19.0" (48.3 cm) loading height | 22.3" (56.4 cm) interior height | 22.8" (57.9 cm) enclosure height | 28.6" (72.6 cm) height w/ monitor | 8.0" (20.3 cm) sash opening  | 58.8" (149.4 cm) height w/cart | 64.6" (164.1 cm) height w/cart & monitor |
| <b>3944301, 3945001 &amp; 3945021</b> | 27.7" (70.4 cm) loading height | 31.5" (80.0 cm) interior height | 32.0" (81.3 cm) enclosure height | 37.9" (96.3 cm) height w/ monitor | 10.0" (25.4 cm) sash opening | 68.0" (172.7 cm) height w/cart | 73.9" (187.7 cm) height w/cart & monitor |



# FilterMate™ Portable Exhausters



*Left to right above:  
FilterMate Portable Exhauster  
3970000. Includes HEPA filter.*

*FilterMate Portable Exhauster  
3970001. Requires carbon  
filter (not included).*

*FilterMate Portable Exhauster  
3970003. Includes HEPA filter.  
Requires carbon filter (not  
included).*

*Left: FilterMate Portable  
Exhauster 3970002. Includes  
HEPA filter and thimble con-  
nection. Requires ducting  
to outside.*

An accessory for the Protector XVS Ventilation Station, Protector Demonstration Hood and Protector Work Station, the FilterMate Portable Exhauster uses a HEPA filter, carbon filter or a combination of both to remove hazardous powders, particulates or vapors from the exhaust air stream and return filtered air to the environment.

## All models feature:

- ▲ Compact, corrosion-resistant housing of powder-coated steel with rubber feet.
- ▲ Variable-speed, non-sparking motorized impeller.
- Quiet operation. Oversized HEPA filter, efficient impeller and perforated exhaust cover work together to provide lower system exhaust velocity and noise pressure levels.

| Exhaust CFM | Noise Pressure dB(A) |
|-------------|----------------------|
| 100         | 45-47                |
| 150         | 51-54                |
| 200         | 56-61                |
| 250         | 63-65                |

- Inherently safe design. A negative pressure plenum surrounds the positive pressure impeller so that if a leak occurs, the unfiltered air is captured and refiltered.
- Sized for Protector Demonstration Hoods, Protector XVS Ventilation Stations and Protector Work Stations. Capable of efficiently filtering up to 250 CFM for HEPA or carbon filtration; up to 200 CFM for combination HEPA/carbon filtration (60-100 fpm depending on enclosure model).
- ▲ Front-mounted rocker switch to control power to the blower.
- Rear-mounted, auxiliary electrical outlet that may be connected to an airflow monitor or other user-supplied accessories.

- Only one FilterMate is required for all 2', 3' and 4' wide enclosures. Multiple FilterMates may be used for 5', 6' and 8' wide enclosures.
- ▲ Included: 8 feet of 5" ID flexible gray polypropylene hose, two clamps and a 4.88" OD Upper Transition Adapter for connection to the top of the Protector XVS Ventilation Station, Protector Work Station or Protector Demonstration Hood. Models 3970004 and 3970024 include a 4.88" OD Lower Transition Adapter instead of the Upper Transition Adapter.
- ▲ 6.5' IEC three-wire electrical cord with plug (115 volt models).
- ▲ 9' IEC three-wire electrical cord. **An electrical plug is required (230 volt models).**
- ▲ ETL listed (115 volt models).

## All models conform to the following regulations and standards:

- ▲ UL\* 61010-1
- ▲ CAN/CSA\* C22.2 No. 61010-1
- ▲ CE\* Conformity Marking (230 volt models)

## Models 3970000, 3970020, 3970002, 3970022, 3970003 and 3970023 feature:

- HEPA filter, 99.99% efficient on particulates 0.3 micron in size.
- ▲ True bag-in/bag-out filter disposal system for safely removing and replacing the filter without detaching the hose. The HEPA filter may be easily accessed by removing the exhaust cover for field leak testing by a certified technician.

## Models 3970002 and 3970022 feature:

- ▲ 6.06" ID thimble connection from the FilterMate to an existing house exhaust system for added safety.

## Models 3970001, 3970021, 3970003 and 3970023 require one each and Models 3970004 and 3970024 require two each (not included):

- ▲ Carbon Filter. Organic Vapor, Formaldehyde or Ammonia Filters are offered. See page 22.

## Optional Accessories

- ▲ Replacement HEPA Filter. See page 22.
- ▲ Replacement Bag-In/Bag-Out Bag. See page 22.
- ▲ Flexible Hose. See page 24.
- ▲ Thimble Connection. See page 24.

\*See page 26 for a list of regulations, standards and registered trademarks.

■ Exclusive Feature





# Ordering Information & Dimensional Data

FILTERMATE™ PORTABLE EXHAUSTERS

## FilterMate™ Portable Exhausters

| Catalog Number | Filter Usage                        | Overall Dimensions          | Electrical Requirements | Airflow Potential      | Exhaust Connection          | Shipping Weight lbs./kg |
|----------------|-------------------------------------|-----------------------------|-------------------------|------------------------|-----------------------------|-------------------------|
| 3970000        | HEPA included                       | 14.0" w x 23.0" d x 22.7" h | 115 volts, 60 Hz        | 250 CFM (60-100 fpm)   | None. Room exhaust.         | 50/23                   |
| 3970020*       | HEPA included                       | 14.0" w x 23.0" d x 22.7" h | 230 volts, 50 Hz        | 250 CFM (60-100 fpm)   | None. Room exhaust.         | 50/23                   |
| 3970001        | Carbon required†                    | 14.0" w x 23.0" d x 22.7" h | 115 volts, 60 Hz        | 250 CFM (60-100 fpm)   | None. Room exhaust.         | 48/22                   |
| 3970021*       | Carbon required†                    | 14.0" w x 23.0" d x 22.7" h | 230 volts, 50 Hz        | 250 CFM (60-100 fpm)   | None. Room exhaust.         | 48/22                   |
| 3970002        | HEPA included                       | 18.6" w x 23.0" d x 24.7" h | 115 volts, 60 Hz        | 250 CFM (60-100 fpm)   | 6.06" ID Thimble to outside | 54/25                   |
| 3970022*       | HEPA included                       | 18.6" w x 23.0" d x 24.7" h | 230 volts, 50 Hz        | 250 CFM (60-100 fpm)   | 6.06" ID Thimble to outside | 54/25                   |
| 3970003        | HEPA included††<br>Carbon required† | 14.9" w x 23.0" d x 22.7" h | 115 volts, 60 Hz        | 200 CFM (60-100 fpm)** | None. Room Exhaust.         | 52/24                   |
| 3970023*       | HEPA included††<br>Carbon required† | 14.9" w x 23.0" d x 22.7" h | 230 volts, 50 Hz        | 200 CFM (60-100 fpm)** | None. Room Exhaust.         | 52/24                   |
| 3970004        | Two Carbon required†                | 14.9" w x 23.0" d x 22.7" h | 115 volts, 60 Hz        | 200 CFM (60-100 fpm)** | None. Room Exhaust.         | 52/24                   |
| 3970024        | Two Carbon required†                | 14.9" w x 23.0" d x 22.7" h | 230 volts, 50 Hz        | 200 CFM (60-100 fpm)** | None. Room Exhaust.         | 52/24                   |

\* International electrical configuration. † Carbon Filter is not included. †† HEPA filter may be removed and substituted with a second carbon filter. \*\* 60-80 fpm on 4' enclosure.

**Models 3970000, 3970001,  
3970020 & 3970021**

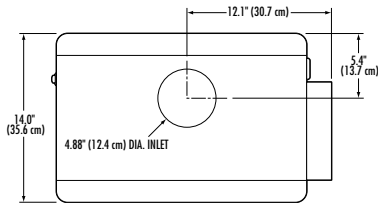

**TOP**

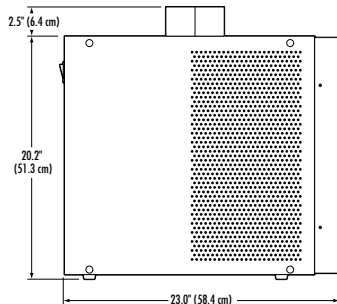

**SIDE**

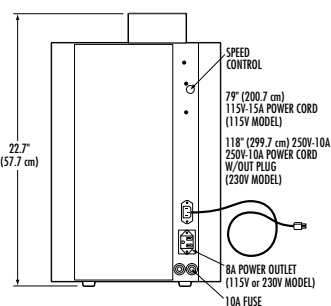

**REAR**

**Models 3970002 & 3970021**

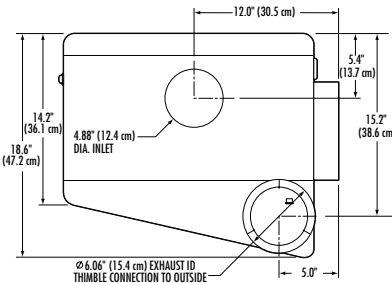

**TOP**

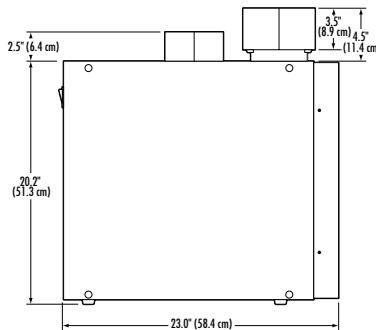

**SIDE**

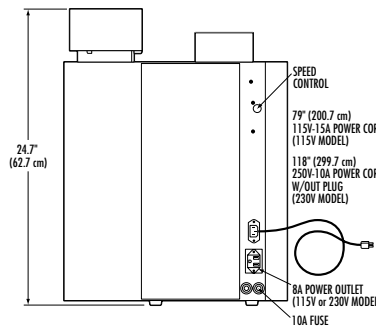

**REAR**

**Models 3970003 & 3970023**

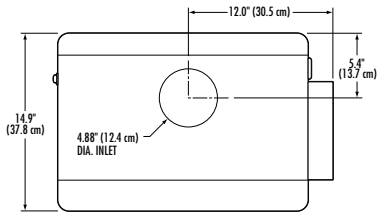

**TOP**

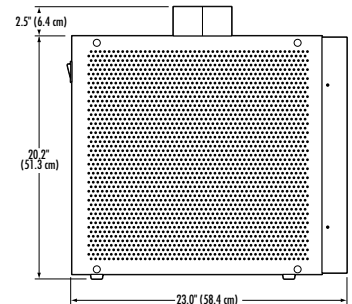

**SIDE**

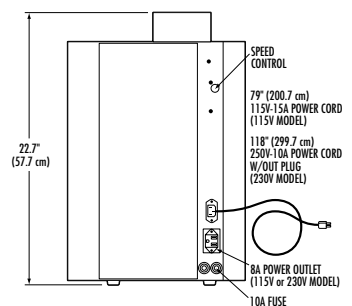

**REAR**



## Carbon and HEPA Filters

FILTERMATE™ PORTABLE EXHAUSTERS

The Application Matrix on page 3 provides examples of appropriate uses for FilterMate Carbon and HEPA Filters. Filters are available in four different types—three carbon and one HEPA. Before selecting a FilterMate Portable Exhauster or any Labconco carbon-filtered

enclosure, please complete the online **Chemical Assessment** form available at [www.labconco.com](http://www.labconco.com) or contact Labconco at 816-333-8811 or 800-821-5525. A Labconco specialist will review your application and chemical usage and recommend the enclosure and filters right for you.



### Carbon and HEPA Filters and Accessories for use with FilterMate Portable Exhausters

A HEPA Filter and Bag-In/Bag-Out Bag are included with FilterMate Portable Exhausters designed for use with HEPA filters. One or two Carbon Filters are required for operation with FilterMate Portable Exhausters designed for use with carbon filters.

| Catalog # | Description   | Shipping Wt. lbs./kg |
|-----------|---|----------------------|
| 3923400   | Organic Carbon Filter, Type AC. Contains 12 pounds of granular activated carbon media.                  | 14/6.3               |
| 3923401   | Formaldehyde Carbon Filter, Type ST-1. Contains a minimum of 14 pounds of impregnated carbon media.     | 17/7.7               |
| 3923402   | Ammonia Carbon Filter, Type AC. Contains a minimum of 16 pounds of impregnated carbon media.            | 21/9.5               |
| 3707900   | Replacement HEPA Filter, 99.99% efficient on particles 0.3 micron in size.                              | 10/4.5               |
| 3776002   | Replacement Bag-In/Bag-Out Bag to ensure containment of particulate matter during HEPA filter changing. | 1/0.5                |
| 1968800   | Orange Cinching Strap for Bag-In/Bag-out Bag.   | 1/0.5                |
| 6925700   | Ammonia Detector Tubes, package of 3.   | 0.5/0.2              |
| 6926000   | Formaldehyde Detector Tubes, package of 3.  | 0.5/0.2              |
| 6924900   | Syringe Kit for carbon filter saturation detection.   | 1/0.5                |

Labconco strongly recommends ordering and keeping an extra set of filters to have readily available when filters become saturated and require replacement.

## Accessories

PROTECTOR® XVS™ VENTILATION STATIONS, PROTECTOR® DEMONSTRATION HOODS & PROTECTOR® WORK STATIONS

### Solid Epoxy Work Surfaces

Black work surfaces are contoured to fit the dimensions of Protector XVS Ventilation Stations, Protector Demonstration Hoods and Protector Work Stations and dished to contain spills. One inch thick molded solid epoxy is chemical resistant and fire proof.



| Catalog # | Dimensions (w x d)              | For use with:                                   | Shipping Wt. lbs./kg |
|-----------|---------------------------------|---|----------------------|
| 3908400   | 24.0" x 26.7" (61.0 x 67.8 cm)  | 2' Protector XVS                                | 48/22                |
| 3908401   | 36.0" x 26.7" (91.4 x 67.8 cm)  | 3' Protector XVS, Protector Demonstration Hoods | 72/33                |
| 3908402   | 48.0" x 26.7" (121.9 x 67.8 cm) | 4' Protector XVS, Protector Work Stations       | 96/44                |
| 3908406   | 60.0" x 26.7" (152.4 x 67.8 cm) | 5' Protector XVS – 29.0" deep models            | 120/54               |
| 3908407   | 72.0" x 26.7" (182.9 x 67.8 cm) | 6' Protector XVS – 29.0" deep models            | 144/65               |
| 3908408   | 96.0" x 26.7" (243.8 x 67.8 cm) | 8' Protector XVS – 29.0" deep models            | 192/88               |
| 3908409   | 60.0" x 35.5" (152.4 x 90.2 cm) | 5' Protector XVS – 35.5" deep models            | 160/72               |
| 3908410   | 72.0" x 35.5" (182.9 x 90.2 cm) | 6' Protector XVS – 35.5" deep models            | 192/88               |
| 3908411   | 96.0" x 35.5" (243.8 x 90.2 cm) | 8' Protector XVS – 35.5" deep models            | 255/115              |

### Stainless Steel Work Surfaces

Type 304 stainless steel work surfaces are 0.8" thick, have a one inch deep front spill trough and fit dimensions of the Protector XVS Ventilation Stations. Available in 5', 6' and 8' widths.



| Catalog # | Dimensions (w x d)              | For use with:                        | Shipping Wt. lbs./kg |
|-----------|---------------------------------|--------------------------------------|----------------------|
| 3975500   | 60.0" x 26.7" (152.4 x 67.8 cm) | 5' Protector XVS - 29.0" deep models | 140/64               |
| 3975501   | 60.0" x 35.5" (152.4 x 90.2 cm) | 5' Protector XVS - 35.5" deep models | 180/82               |
| 3975600   | 72.0" x 26.7" (182.9 x 67.8 cm) | 6' Protector XVS - 29.0" deep models | 170/77               |
| 3975601   | 72.0" x 35.5" (182.9 x 90.2 cm) | 6' Protector XVS - 35.5" deep models | 220/100              |
| 3975800   | 96.0" x 26.7" (243.8 x 67.8 cm) | 8' Protector XVS - 29.0" deep models | 240/109              |
| 3975801   | 96.0" x 35.5" (243.8 x 90.2 cm) | 8' Protector XVS - 35.5" deep models | 290/132              |

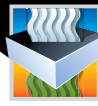

## Accessories

PROTECTOR® XVS™ VENTILATION STATIONS, PROTECTOR® DEMONSTRATION HOODS & PROTECTOR® WORK STATIONS

### 6942003 Work Surface with Sink

For use with Protector Work Stations. Accommodates standard dissecting boards. Molded black solid epoxy is chemical resistant and fire proof. Includes a 10.0" x 14.0" x 6.0" deep (25.4 x 35.6 x 15.2 cm) molded epoxy sink. Fixtures include a chrome-plated gooseneck faucet with vacuum breaker, two chrome-plated faucet controls and a spray nozzle with hose. **Sink requires a 1.5" diameter drain connection.** Dimensions: 48.0" w x 26.8" d x 1.25" thick (121.9 x 68.1 x 91.4 cm). Shipping weight 125 lbs. (57 kg)



### 8026000 Cart for Protector Demonstration Hoods

Provides mobile support for Protector Demonstration Hoods and 3' Protector XVS Ventilation Stations. Glacier white powder-coated tubular steel with black 1" thick solid epoxy dished work surface, handle bar, bottom shelf and 4" diameter toe-locking casters. Supports loads up to 400 pounds. Cart is included with Protector Demonstration Hood Systems 3945000, 3945001, 3945020 and 3945021. Dimensions: 39.0" w x 31.9" d x 36.0" h (99.1 x 81.0 x 91.4 cm). Shipping weight 50 lbs. (23 kg)

### 3925000 Utility Shelves

For use with Protector XVS Ventilation Stations and Protector Work Stations. Three shelves attach to the rear baffle perforations to hold items such as a balance printer, utensils and other miscellaneous supplies. The utensil shelf has scalloped front edge to support scalpels, forceps and other items. Powder-coated steel. Shipping weight 5 lbs. (2 kg)



### 3927700 Bottle Holder

For use with Protector XVS Ventilation Stations and Protector Work Stations. Attaches to the rear baffle perforations to hold a squirt bottle or other round container. Powder-coated steel. 3" diameter opening. Shipping weight 1 lb. (0.5 kg)

### 3927800 Tissue Holder

For use with Protector XVS Ventilation Stations and Protector Work Stations. Attaches to the rear baffle perforations to hold tissue wipers in the upside down position. An opening in the bottom of the holder permits wipers to be dispensed from the bottom. Powder-coated steel. Shipping weight 1 lb. (0.5 kg)



### Fluorescent Task Lights

For use with Protector XVS Ventilation Stations and Protector Demonstration Hoods. May be placed atop the enclosure to enhance illumination of the interior. Include auxiliary electrical receptacle with switch for connection of accessories such as a printer or airflow monitor.

| Catalog # | Description   | Shipping Wt. lbs./kg |
|-----------|---|----------------------|
| 3909200   | 115 volts, 60 Hz, 10 amps. Includes IEC, three-wire cord with plug.                               | 15/7                 |
| 3909201*  | 230 volts, 50 Hz, 10 amps. Includes IEC, three-wire cord. <b>Plug is required (not included).</b> | 15/7                 |

\* International electrical configuration.



## Accessories

PROTECTOR® XVS™ VENTILATION STATIONS, PROTECTOR® DEMONSTRATION HOODS & PROTECTOR® WORK STATIONS



### 5248300 Waste Chute Stopper

For use with 5', 6' and 8' Protector XVS Ventilation Stations, 35.5" deep, with waste chute. When waste chute is not in use, the stopper helps prevent contaminants from escaping from the enclosure through the side wall. Solid rubber. 5" diameter. Shipping weight 1 lb. (0.5 kg)

### Flexible Hoses for FilterMate™ Portable Exhauster

For use with the FilterMate Portable Exhauster instead of the flexible polypropylene hose included. 8' length. Include two clamps.

| Catalog # | Description   | Shipping Wt. lbs./kg |
|-----------|---|----------------------|
| 3927500   | 5" ID, clear urethane, smooth bore with white helix, static dissipative, suitable for pharmaceutical and clean room applications.   | 3/1                  |
| 3927600   | 6" ID, black thermoplastic rubber hose with 6.09" ID cuffs, suitable for pharmaceutical and clean room applications. May be used to duct to the outside.<br><b>Requires 3927400 Adapter, 5" Round to 6" Round, sold separately.</b> | 3/1                  |

### 3913600 Thimble Connection Kit

For retrofitting FilterMate Portable Exhausters 3970000, 3970020, 3970001, 3970004 and 3970024. Included with FilterMate Portable Exhausters 3970002 and 3970022. Shipping weight 10 lbs. (4 kg)



### Guardian™ 1000 Digital Airflow Monitors

Mount atop Protector XVS Ventilation Stations, Protector Demonstration Hoods and Protector Work Stations in factory-prepared location. Monitor and alert the operator to low airflow conditions. Include face plate with circuit board, electrical power pack, airflow hose, flow hose adapter and glacier white powder-coated steel casing. LCD displays actual airflow in fpm or m/sec from 0 to 999 fpm (0 to 5.0 m/s). Audible/visual alarm alerts user to sustained low velocity condition. Calibration instructions displayed on LCD. LED lights display red for alarm, yellow for caution, green for normal. Include temperature-compensated sensor, external alarm, RS-232 port, night setback and alarm mute functions. UL and CE listed\*\*.

| Catalog # | Electrical Requirements | Shipping Wt. lbs./kg |
|-----------|-------------------------|----------------------|
| 3908800   | 115 volts, 60 Hz        | 10/4.5               |
| 3908801*  | 230 volts, 50 Hz        | 10/4.5               |



### Guardian™ 500 Airflow Monitors

Mount atop Protector XVS Ventilation Stations, Protector Demonstration Hoods and Protector Work Stations in factory-prepared location. Include face plate with circuit board, electrical power pack, tubing, airflow tube adapter and glacier white powder-coated steel casing. From the monitor's face plate, the user can easily select and calibrate a setpoint between 30 and 250 fpm using a velocity meter and a screwdriver. A green LED glows to indicate "safe" when airflow is greater than the low setpoint. A red LED flashes to indicate "low" when airflow is below the low setpoint. An amber LED flashes when the sash is raised above the maximum safe working opening. An audible alarm sounds (and can be muted) when under "low" and "sash high" conditions. Include night setback, external alarm and alarm mute functions.

| Catalog # | Electrical Requirements | Shipping Wt. lbs./kg |
|-----------|-------------------------|----------------------|
| 3944700   | 115 volts, 60 Hz        | 10/4.5               |
| 3944701*  | 230 volts, 50 Hz        | 10/4.5               |

\*International electrical configuration.

\*\*See page 26 for a list of regulations, standards and registered trademarks.





# Accessories

PROTECTOR® XVS™ VENTILATION STATIONS, PROTECTOR® DEMONSTRATION HOODS & PROTECTOR® WORK STATIONS



## Remote Blowers

A remote blower is required when ducting the Protector XVS Ventilation Station, Protector Demonstration Hood or Protector Work Station to the outside. The direct drive blower has a 1/4 hp TEFC-type motor and overcomes external static pressure of 0.5" at 420 CFM. Housing and impeller are corrosion-resistant, phenolic-coated steel. Blower inlet is 5.94" OD and is sized to accept 6" nominal diameter PVC duct. Blower outlet is 4.25" x 7.38" OD (10.8 x 18.7 cm). Dimensions: 14.6" w x 13.5" d x 13.25" high (37.1 x 34.3 x 33.7 cm).

| Catalog #        | Electrical Requirements            | Shipping Wt. lbs./kg |
|------------------|------------------------------------|----------------------|
| <b>4863500</b>   | 115 volts, 60 Hz, 4.4 amps         | 35/16                |
| <b>4863501*</b>  | 115/230 volts, 50 Hz, 5.6/2.8 amps | 35/16                |
| <b>7053501**</b> | 115 volts, 60 Hz 4.4 amps          | 40/18                |

\*International electrical configuration. \*\*Explosion-proof

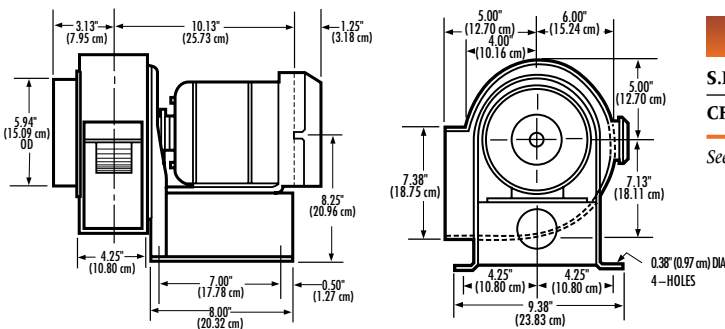

| CFM @ Static Pressure—Inches of H <sub>2</sub> O |      |        |       |       |       |       |
|--|------|--------|-------|-------|-------|-------|
| S.P.   | 0.0" | 0.125" | 0.25" | 0.50" | 0.75" | 0.87" |
| CFM  | 595  | 560    | 515   | 420   | 300   | 167   |

See Blower Booklet for more information.

## Exhaust Transition Adapters

For use with Protector XVS Ventilation Stations, Protector Demonstration Hoods and Protector Work Stations designed for outside ducting or connected to the FilterMate Portable Exhauster. Chemical resistant, rotational molded polyethylene.

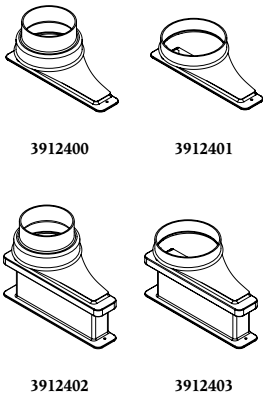

| Catalog #      | Description   | Shipping Wt. lbs./kg |
|----------------|---|----------------------|
| <b>3912400</b> | Upper Exhaust Transition Adapter, one-piece molded polyethylene, 2" x 10" rectangular to 5" diameter round for connection to 5" ID hose (included with FilterMate Portable Exhauster) | 5/2                  |
| <b>3912401</b> | Upper Exhaust Transition Adapter, one-piece molded polyethylene, 2" x 10" rectangular to 6" diameter round for connection to 6" OD duct   | 5/2                  |
| <b>3912402</b> | Lower Exhaust Transition Adapter, one-piece molded polyethylene, 2" x 10" rectangular to 5" diameter round for connection to 5" ID hose   | 5/2                  |
| <b>3912403</b> | Lower Exhaust Transition Adapter, one-piece molded polyethylene, 2" x 10" rectangular to 6" diameter round for connection to 6" OD duct   | 5/2                  |

## Ductwork

| Catalog #      | Description   | Equivalent Resistance <sup>†</sup> | Shipping Wt. lbs./kg |
|----------------|---|------------------------------------|----------------------|
| <b>4708600</b> | Thermoplastic Duct, 6.625" OD, 6.250" ID, 10' length  | 10'                                | 25/11                |
| <b>4708900</b> | Female PVC Duct Coupling, 6" nominal diameter, connects two sections of Thermoplastic Duct                                  | 0'                                 | 4/2                  |
| <b>4708700</b> | 90° PVC Elbow, 6" nominal diameter, has belled end connections to directly receive Thermoplastic Duct or Male Duct Coupling | 12'                                | 1/0.5                |
| <b>3924000</b> | Manual Exhaust Damper, powder-coated steel, 6" nominal diameter   | 1'                                 | 1/0.5                |
| <b>4724200</b> | Manual Exhaust Damper, PVC, 6" nominal diameter   | 1'                                 | 1/0.5                |
| <b>4861800</b> | Flexible Duct Connection, 7" nominal diameter, for use with 6" nominal diameter duct  | 1'                                 | 8/4                  |
| <b>4861700</b> | Blower Transition Adapter, 4.25" x 7.75" rectangle to 6" diameter round   | 1'                                 | 3/1                  |
| <b>4722200</b> | Zero Pressure Weathercap, 6" nominal diameter, fits atop Thermoplastic Duct   | 5'                                 | 20/9                 |

<sup>†</sup>Equivalent resistance is measured in feet of straight duct.



# Standards & Registered Trademarks

## Standards

Key aspects of standards and codes as they relate to ductless enclosures are summarized below.

### ASHRAE 110-1995 Method of Testing Performance of Laboratory Fume Hoods (ANSI Approved)

Evaluates fume hood's containment characteristics

- ▲ Three part test: Smoke generation, face velocity profile, tracer gas release @ 4 liters per minute.
- ▲ Rated As Manufactured (AM), As Installed (AI) and As Used (AU).

Labconco comment: For Paramount Ductless Enclosures and Protector Work Stations, the ASHRAE test is modified to accommodate the enclosures' fixed sash heights.

### American Society of Heating, Refrigerating and Air-Conditioning Engineers

1791 Tullie Circle NE  
Atlanta, GA 30329  
(404) 636-8400  
www.ashrae.org

### ANSI Z9.5-2011 Standard—Laboratory Ventilation

Covers entire laboratory ventilation system.

- ▲ New and remodeled hoods shall have a monitoring device.
- ▲ Ductless hoods should only be used with non-hazardous materials.

### American Industrial Hygiene Association

2700 Prosperity Avenue, Suite 250  
Fairfax, VA 22031  
(703) 849-8888  
www.aiha.org

### SEFA 1-2010 Laboratory Fume Hoods Recommended Practices

- ▲ Fume hood face velocities based on toxicity levels of chemicals.
- ▲ Test method—face velocity profile and smoke generation.

### SEFA 9-2010 Recommended Practices for Ductless Enclosures

- ▲ Ductless hoods do not have the same scope of application as standard fume hoods, biological safety cabinet or potent compound hoods.
- ▲ Ductless filtration categories are defined as:
  - DH I—Has a filtration device to control non-toxic chemicals, nuisance odors, particulates.
  - DH II—Meets DH I requirements plus equipped with a filtration device to filter manufacturer approved toxic contaminants up to filter break through only.
  - DH III—Meets DH I and II requirements plus equipped with a filtration device to filter manufacturer approved toxic contaminants beyond primary breakthrough by providing secondary back-up protection..
- ▲ Prior to approving usage, the manufacture should review all applications and determine the compatibility or incompatibility of the ductless hood.
- ▲ DH II/III hoods require constant monitoring of filter saturation breakthrough and should have a continuous audible and visual automatic saturation detection monitoring device. The device on DH II hoods should detect breakthrough so that measurements taken downstream from the filter does not exceed 50% of the TLV of the contaminant(s). The device on DH III hoods should detect breakthrough so that measurements taken downstream from the filter does not exceed 1% of the TLV of the contaminants(s).
- ▲ DH II/III hoods should have a permanent face velocity monitoring device.

### SEFA 8-2010 Recommended Practices For Metal Laboratory Grade Furniture, Casework, Shelving and Tables, 8.0 Cabinet Surface Finish Tests

- ▲ Laboratory grade paint finishes shall withstand chemical exposure, hot water, and impact from a one-pound ball dropped from 12".
- ▲ Paint coating shall sufficiently adhere to the substrate.
- ▲ Paint shall be resistant to scratches.

### Scientific Equipment & Furniture Association

1205 Franklin Avenue  
Suite 320  
Garden City, NY 11530  
(516) 294-5424  
www.sefalabs.com

### UL 61010-1 Electrical Equipment for Laboratory Use

Specifies the general safety requirements for electrical equipment

- ▲ Based on International Electrotechnical Commission (IEC) Publication 61010-1 with differences noted for U.S. use.
- ▲ Protection against electrical shock, mechanical hazards, spread of fire, radiation, liberated gases, explosion and implosion.
- ▲ Resistance to shock, vibration, impact, heat, moisture and liquids.

### Underwriters Laboratories Inc.

333 Pfingsten Road  
Northbrook, IL 60062-2096  
(847) 272-8800  
www.ul.com

### CAN/CSA Standard C22.2 No. 61010-1 Safety Requirements for Electrical Equipment for Measurement, Control and Laboratory Use

Specifies general safety requirements for electrical equipment

- ▲ Design and methods of construction should provide adequate protection to the operator and the surrounding area against shock or burn, mechanical hazards, excessive temperature, spread of fire from the equipment, gas liberation, explosion or implosion.

### Canadian Standards Association

5060 Spectrum Way, Suite 100  
Mississauga, Ontario  
L4W 5N6  
CANADA  
(800) 463-6727 or (416) 747-4044  
www.csa.ca

### ETL listing

ETL (formerly Edison Testing Laboratories) is a Nationally Recognized Testing Laboratory (NRTL). The ETL mark signifies that a product conforms to the following:

- ▲ UL Standard 3101-1 in the U.S.
- ▲ CAN/CSA Standard C22.2 No. 1010.1 in Canada.
- ▲ Products that bear the ETL mark are subjected to a comprehensive safety program that includes testing, listing, labeling and quarterly follow-up inspections.

### Intertek Group

www.intertek.com

### CE Marking

Indicates an electrical apparatus conforms to all safety and other directives/specifications presently required by the Council of European Communities.

- ▲ Electrical safety.
- ▲ Electromagnetic emissions testing—interference signals being output by the product.
- ▲ Electromagnetic immunity testing—the product does not respond to outside electromagnetic interference signals.

### European Union

www.europa.eu

## Registered Trademarks

AutoCAD® is a registered trademark of AutoDesk, San Rafael, California.

ANSI® is a registered trademark of American National Standards Institute.

SafeBridge® is a registered trademark of SafeBridge Consultants, Inc., Mountain View, California.

SEFA® is a registered trademark of Scientific Equipment and Furniture Association.

UL® is a registered trademark of UL, LLC.



*Contact Labconco at 800-821-5525 or 816-333-8811  
for more information about these quality products for your laboratory.*



HEPA-Filtered Biological Safety Cabinets, Enclosures & Clean Benches



Laboratory Fume Hoods



Balance & Bulk Powder Enclosures



Laboratory Animal Research Stations



Nanotechnology Enclosures



Forensic Enclosures



Glove Boxes



Glassware Washers



Water Purification Systems



Freeze Dry Systems



Agricultural Chemistry Apparatus



Vacuum Concentrators & Cold Traps



Multiple Sample Evaporation Systems



Laboratory Carts & Benches



Blood Drawing Chairs



**Labconco Corporation**

8811 Prospect Avenue  
Kansas City, Missouri 64132-2696  
816-333-8811 or 800-821-5525  
FAX 816-363-0130  
labconco@labconco.com  
www.labconco.com

